

Convex Computer Corporation
3000 Waterview Parkway
P.O. Box 833851
Richardson, TX 75083-3851
United States of America
(214)497-4000

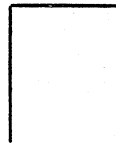

CONVEX ESDI Disk System Service Guide

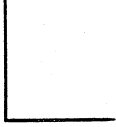

Order No. DHW-282

Second Edition
June 1992

CONVEX Press
Richardson, Texas
United States of America

CONVEX Removable Disk System Installation Guide

Order No. DHW-282

Copyright ©1992 CONVEX Computer Corporation
All rights reserved.

This document is copyrighted. All rights reserved. This document may not, in whole or part, be copied, duplicated, reproduced, translated, electronically stored, or reduced to machine readable form without prior written consent from CONVEX Computer Corporation.

Although the material contained herein has been carefully reviewed, CONVEX does not warrant it to be free of errors or omissions. CONVEX reserves the right to make corrections, updates, revisions, or changes to the information contained herein. CONVEX does not warrant the material described herein to be free of patent infringement.

UNLESS PROVIDED OTHERWISE IN WRITING WITH CONVEX COMPUTER CORPORATION (CONVEX), THE EQUIPMENT DESCRIBED HEREIN IS PROVIDED "AS IS" WITHOUT WARRANTY OF ANY KIND, EITHER EXPRESSED OR IMPLIED, INCLUDING, BUT NOT LIMITED TO, THE IMPLIED WARRANTIES OF MERCHANTABILITY AND FITNESS FOR A PARTICULAR PURPOSE. SOME STATES DO NOT ALLOW THE EXCLUSION OF IMPLIED WARRANTIES. THE ABOVE EXCLUSION MAY NOT BE APPLICABLE TO ALL PURCHASERS BECAUSE WARRANTY RIGHTS CAN VARY FROM STATE TO STATE. IN NO EVENT WILL CONVEX BE LIABLE TO ANYONE FOR SPECIAL, COLLATERAL, INCIDENTAL, OR CONSEQUENTIAL DAMAGES, INCLUDING ANY LOST PROFITS OR LOST SAVINGS, ARISING OUT OF THE USE OR INABILITY TO USE THIS EQUIPMENT. CONVEX WILL NOT BE LIABLE EVEN IF IT HAS BEEN NOTIFIED OF THE POSSIBILITY OF SUCH DAMAGE BY THE PURCHASER OR ANY THIRD PARTY.

CONVEX and the CONVEX logo ("C") are registered trademarks of CONVEX Computer Corporation
CONVEX C100 Series and C200 Series are trademarks of CONVEX Computer Corporation
ConvexOS is a trademark of CONVEX Computer Corporation
C1, C120, C201, C202, C210, C220, C230, and C240 are trademarks of CONVEX Computer Corporation
UNIX is a registered trademark of UNIX System Laboratories, Inc.

Printed in the United States of America

Revision Information for

**CONVEX
ESDI Disk System
Service Guide**

| Edition | Document No. | Description |
|----------------|---------------------|---|
| Second | 081-013730-001 | June 1992. This edition includes information for the Micropolis 1.5-Gbyte disk drive. |
| First | 081-013730-000 | September 1991. First release. |

FCC Notice

Note

This equipment generates, uses, and can radiate radio frequency energy. And, if not installed and used in strict accordance with the instruction manual, it may cause harmful interference to radio communications.

This equipment has been tested and found to comply with the limits for a Class A digital device, pursuant to Part 15 of the FCC Rules. These limits are designed to provide reasonable protection against harmful interference when the equipment is operated in a commercial environment.

When this equipment is operated in a residential area, it is likely to cause interference. In this case, the interference must be corrected at the operator's expense.

Do not connect external equipment to the utility outlets in CONVEX equipment cabinets. Unauthorized connection voids all agencies' emissions certification.

Contents

| | | |
|----------|--|-----------|
| 1 | Description and specifications | 1 |
| | Overview | 1 |
| | ESDI disk system specifications | 4 |
| 2 | Unpacking and installation | 7 |
| | Overview | 7 |
| | Unpacking and inspection | 7 |
| | Electrostatic discharge damage | 7 |
| | Inspection for damage | 8 |
| | Unpacking | 8 |
| | Damage claims | 9 |
| | Preinstallation | 9 |
| | Installing an ESDI chassis into an expansion cabinet | 14 |
| | Installing a drive into an ESDI chassis | 19 |
| | Postinstallation | 27 |
| 3 | Integration and test | 29 |
| | Overview | 29 |
| | Software integration | 29 |
| | Testing the ESDI disk system | 31 |
| 4 | Maintenance procedures and IPB | 33 |
| | Overview | 33 |
| | Maintenance procedures | 33 |
| | Preservice procedures | 33 |
| | ESDI drive unit removal and replacement | 36 |
| | Removal | 38 |
| | Replacement | 38 |
| | Power supply removal and replacement | 39 |
| | 5-volt power supply removal | 41 |
| | 5-volt power supply replacement | 41 |
| | 12-volt power supply removal | 41 |
| | 12-volt power supply replacement | 41 |
| | ESDI chassis cooling fan removal and replacement | 43 |
| | Removal | 44 |
| | Replacement | 44 |
| | ESDI chassis power breaker | 44 |

| | |
|---|----|
| Removal | 44 |
| Replacement | 45 |
| ESDI chassis power switch removal and replacement | 45 |
| Removal | 45 |
| Replacement | 45 |
| ESDI chassis temperature sensor | 46 |
| Removal | 46 |
| Replacement | 46 |
| Postservice procedures | 46 |
| ESDI chassis and ESDI drive IPB | 48 |

A Hitachi 780MB ESDI Disc Drive Configurator 57

B Micropolis 1.53GB ESDI Disc Drive Configurator 63

Index 67

Figures

| | | |
|-----------|--|----|
| Figure 1 | ESDI chassis with four drives (front view) | 2 |
| Figure 2 | One controller four drive ESDI system | 3 |
| Figure 3 | Front panel power switch | 10 |
| Figure 4 | EXP-105 power controller | 11 |
| Figure 5 | VMEbus chassis power control switch | 12 |
| Figure 6 | Expansion cabinet stabilizer bars | 13 |
| Figure 7 | ESDI chassis I/O panel | 15 |
| Figure 8 | ESDI chassis cable connection | 16 |
| Figure 9 | Front panel mounting bracket | 18 |
| Figure 10 | ESDI chassis power switch | 19 |
| Figure 11 | ESDI disk drive position in ESDI chassis | 22 |
| Figure 12 | Cable connections (4 drives/controller) | 24 |
| Figure 13 | Cable connections (2 drives/controller) | 25 |
| Figure 14 | Front panel power switch | 27 |
| Figure 15 | Example /ioconfig file | 31 |
| Figure 16 | VMEbus chassis power control switch | 34 |
| Figure 17 | Expansion cabinet stabilizer bars | 35 |
| Figure 18 | ESDI chassis power switch | 36 |
| Figure 19 | ESDI disk unit | 37 |
| Figure 20 | ESDI drive power supply | 40 |
| Figure 21 | ESDI chassis fan and power control FRUs | 43 |
| Figure 22 | ESDI drive IPB | 49 |
| Figure 23 | Power supply IPB | 51 |
| Figure 24 | Fan, sensor, breaker and switch IPB | 53 |

Tables

| | | |
|---------|--|----|
| Table 1 | ESDI disk physical specifications | 4 |
| Table 2 | ESDI chassis specifications (four drives) | 4 |
| Table 3 | System software requirements | 5 |
| Table 4 | Static charge levels and relative humidity | 8 |
| Table 5 | Disk drive list | 48 |
| Table 6 | Power supply list | 50 |
| Table 7 | Fan, sensor, breaker and switch list | 52 |
| Table 8 | Cabling list | 54 |
| Table 9 | Miscellaneous parts list | 55 |

How to use this guide

Purpose and audience

The *CONVEX ESDI Disk System Service Guide* provides a general overview of the 780-Mbyte and the 1.5-Gbyte ESDI disk drives, related hardware, and how to:

- Install the ESDI disk drive, ESDI chassis, and related hardware.
- Integrate the ESDI disk drive into the CONVEX operating system (ConvexOS).
- Test the ESDI drive and related hardware.
- Remove and replace the ESDI drive and related hardware.

This document is intended for:

- CONVEX customer support engineers and CONVEX manufacturing personnel
- CONVEX customers who need to install and maintain their own ESDI disk system and related hardware

Scope

The information presented in this service guide applies exclusively to the 780-Mbyte and 1.5-Gbyte ESDI disk systems, when installed in an ESDI Chassis.

Organization

This document consists of the following sections:

- **Chapter 1, "Description and specifications"**—Describes the ESDI disk system and related hardware at the block-diagram level. This chapter also defines and lists the electromechanical and environmental specifications.

- **Chapter 2, "Unpacking and installing"**—Provides guidelines on how to unpack and install the ESDI drive, ESDI chassis, and related hardware.
- **Chapter 3, "Integration and test"**—Explains how to integrate the ESDI disk system into the ConvexOS operating system and how to test the ESDI disk system.
- **Chapter 4, "Maintenance procedures and IPB"**—Provides removal and replacement instructions for the ESDI drive, ESDI chassis, and related hardware. It also gives the illustrated parts breakdown for the ESDI disk system.
- **Appendix A, "Hitachi 780-Mbyte ESDI Disc Drive Configurator"**—Contains the *Hitachi 780-Mbyte ESDI Disc Drive Configurator*.
- **Appendix B, "Micropolis 1.53-Gbyte ESDI Disc Drive Configurator"**—Contains the *Micropolis 1.53-Gbyte ESDI Disc Drive Configurator*.

Notational conventions

Notational conventions are those systems of characters, symbols, terminology, or abbreviated expressions used to express technical facts or quantities as established by this guide. The following notational conventions are used in this document:

- *Italic*:
 - Designates user-supplied variables in a command-line example
 - Designates variable fields in data descriptors
 - Introduces new and important terms
 - Indicates document titles
- **Bold constant-width font**:
 - Indicates user input that must be typed exactly as shown
- **Constant-width font** designates input and output, including:
 - Command names and options
 - System calls
 - Data structures and types
 - Directives, program statements, display examples, printout examples, and error messages

- Horizontal ellipsis (...) shows repetition of the preceding item(s)
- Vertical ellipsis indicate that lines of input or output have been left out of an example
- All CONVEX illustrations have an illustration file number at the bottom right-hand corner that is for CONVEX use only.

Warnings

The following is an example of a warning and its content and locations as used in CONVEX documents:

Warning

A warning highlights procedures or information necessary to avoid injury to personnel. The warning immediately precedes the critical information and includes a description of the hazard.

Cautions

The following is an example of a caution and its content and locations as used in CONVEX documents:

Caution

A caution highlights procedures or information necessary to avoid damage to equipment, damage to software, loss of data, or that leads to invalid test results. The caution immediately precedes the critical information and includes a description of the possible damage.

Notes

The following is an example of a note and its typical content:

Note

A note highlights information of a supplemental nature. The note immediately precedes or follows the highlighted information.

Associated documents

The following is a partial list of manuals that may provide more detailed information on the topics presented in this manual:

- *CONVEX VME ESDI Disk Controller Service Guide*, Document No. 081-000130-201, (DHW-053)
- *Managing ConvexOS: Configuration Guide* (DSW-030)
- *Managing ConvexOS: Operations Guide* (DSW-031)
- *CONVEX VMEbus SMD/ESDI Disk and Formatter (dev5130) Diagnostics Manual* (DHW-242)
- *Hitachi DK515 Winchester Disk Drive Service Guide* (CONVEX Part No. 900-000347-001)
- *Hitachi 780-Mbyte ESDI Disc Drive Configurator* (CONVEX Part No. 204-000019-600)
- *Interphase 4201 (ESDI) Disc Controller Configurator* (CONVEX Part No. 220-000011-600)
- *Interphase 4201 (ESDI) Disc Controller (Fast) Configurator* (CONVEX Part No. 220-000025-600)
- *Micropolis 1518 Technical Manual* (CONVEX Part No. 900-000494-001)
- *Micropolis 1.53 Gbyte ESDI Disc Drive Configurator* (CONVEX Part No. 204-000025-200)

Ordering documents

To order the current edition of this or any other CONVEX document, send requests to:

CONVEX Computer Corporation
Customer Service
PO Box 833851
Richardson TX 75083-3851 USA

Include the order number with the request. The order number is on the title page of the manual and begins with the letters "DHW" or "DSW."

Technical assistance

Hardware, software, and documentation support can be obtained through the CONVEX Technical Assistance Center :

- From all locations in the continental United States, call (800)952-0379.
- From locations in Alaska, Hawaii, and Canada, call (214)497-4379.
- From all other locations, contact the nearest CONVEX office.

Description and specifications

1

Overview

The CONVEX ESDI disk system is a high-capacity VME-based disk storage system contained in a standard 19-inch rack-mountable chassis. The system can be configured using either 650-Mbyte (formatted capacity) or 1.3-Gbyte (formatted capacity) ESDI disk drives. Each chassis can accommodate up to four ESDI disk drives, yielding a maximum storage capacity of 5.2-Gbytes when using the larger 1.3-Gbyte disk drives. The ESDI disk drives have the following features:

- VME-based enhanced small device interface (ESDI)
- Peak data transfer rate for 780-Mbyte drive is 2.46-Mbytes/s
- Peak data transfer rate for 1.5-Gbyte drive is 2.9-Mbytes/s
- 780-Mbyte drive average seek time=16 ms
- 1.5-Gbyte drive average seek time = 14.5 ms

Figure 1 shows the front panel of an ESDI chassis designed to hold four drives.

Figure 1
ESDI chassis with four drives (front view)

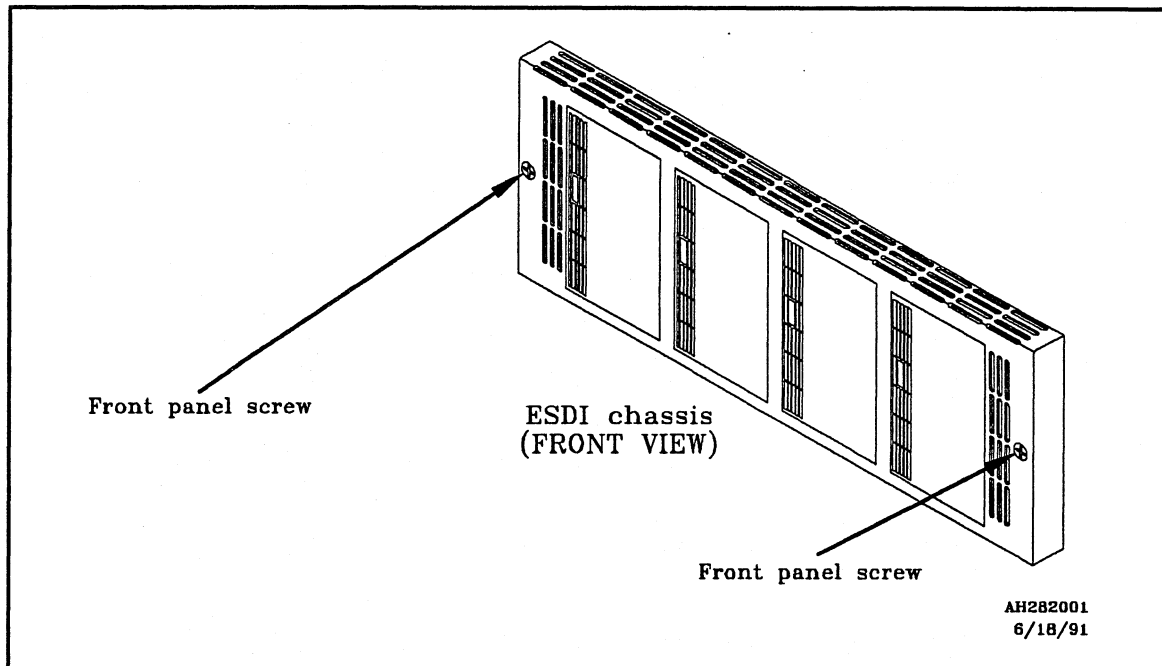

Note

For more detailed information concerning the 780-Mbyte ESDI drive refer to the *Hitachi DK515 Winchester Disk Drive Service Manual*. For more detailed information concerning the 1.5-Gbyte ESDI drive refer to the *Micropolis 1518 Technical Manual*.

The CONVEX ESDI disk system can be configured with one or two VME/ESDI disk controllers: CONVEX systems running ConvexOS V8.1, V9.0 and V9.1 can support a maximum of two disk drives per controller. ConvexOS V10.0 and greater can support up to four disk drives per controller. ConvexOS V10.1 or higher is required for the 1.5-Gbyte drives. Refer to Chapter 3, "Integration and test," for more information.

One control cable is required from each VME/ESDI disk controller to the ESDI chassis. Internal control ribbon cables connect from one to four disk drives together in the chassis. In addition to the control cable, a single data cable is required for each disk drive in the ESDI chassis. Figure 2 shows a block diagram of a one controller/four drive configuration.

Figure 2
One controller four drive ESDI system

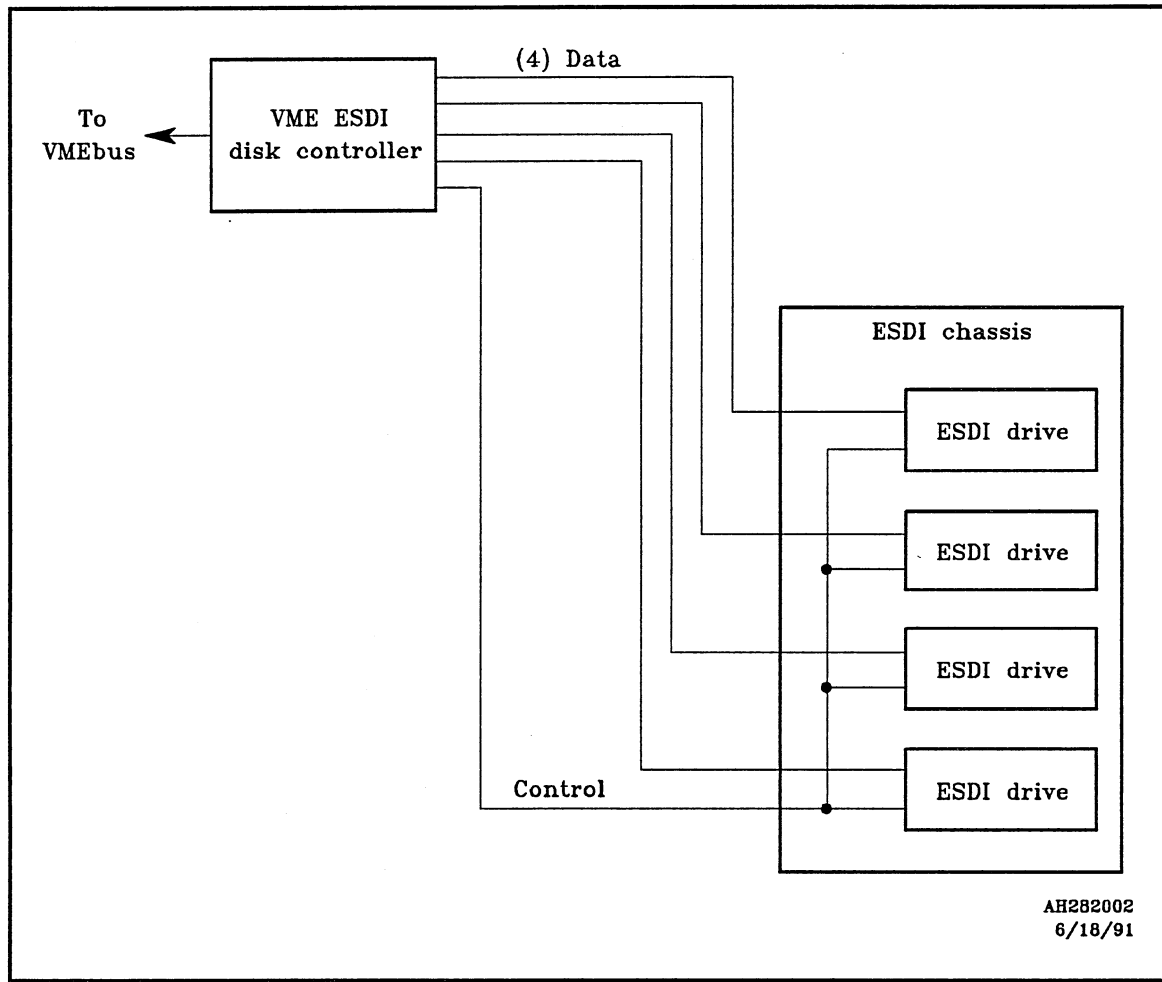

ESDI disk system specifications

This section gives the physical and operational specifications listed in Table 1, Table 2 and Table 3 for the ESDI disk drive system.

Table 1
ESDI disk physical specifications

| Parameter | Value/comment |
|-----------|--|
| Width | 5.7 in (146 mm) |
| Height | 3.25 in (82.5 mm) |
| Depth | 8.0 in (203 mm) |
| Weight | 780-Mbyte—7.7 lbs (3.5 kg) 1.5-Gbyte—8.2 lbs (3.7 kg) |

Table 2
ESDI chassis specifications
(four drives)

| Parameter | Value/comment |
|--------------------------------|--|
| Width | 19.0 in (48.26 cm) |
| Height | 7.0 in (17.78 cm) |
| Depth | 17.5 in (44.45 cm) |
| Weight | Chassis without drives 38 lbs (17.7 kg) |
| Voltage range Domestic | 2.66 amps @ 120 Vac in chassis with 4 drives |
| International | 1.33 amps @ 240 Vac in chassis with 4 drives |
| Temperature range Operating | +59° F to +90° F (+15° C to +32° C) |
| Non operating | -4° F to +140° F (-40° C to +60° C) |
| Temperature change | ≤ 18° F/h (10° C/h) |
| Humidity range Operating | 40% to 60% noncondensing |
| Non operating | 8% to 90% noncondensing |
| Wet bulb | 780-Mbyte 84.2° F (29° C) 1.5-Gbyte 80° F (26.7° C) |
| Altitude Operating | 9842.5 ft. (3000 m) |
| Non operating | 40,000 ft. (12,000 m) |

Table 3
System software
requirements

| Drive | Version | Comments |
|--------------------|------------------------------------|--|
| 780-Mbyte drive | ConvexOS V8.1, V9.0 and V9.1 | Supports a maximum of two drives per controller |
| | ConvexOS V10.0 or higher | Supports up to four drives per controller without a system generation |
| 1.5-Gbyte drive | ConvexOS V10.1 or higher | Required for 1.5-Gbyte drives |

Unpacking and installation

2

Overview

This chapter discusses unpacking and inspecting the equipment, identifies major components of the ESDI disk system, and provides installation procedures.

Unpacking and inspection

This section gives general guidelines for unpacking and inspecting the ESDI disk drive system and provides safety and equipment damage precaution information.

Electrostatic discharge damage

Typically, electrostatic discharge (ESD) damage occurs to electronic circuit boards during handling. Static charges take place when various objects are separated or rubbed together, often creating a high-voltage charge. If a high-voltage charge is discharged into electronic computer circuits, the charge damages the electronic components. The main factors that determine a voltage level charge are:

- Types of materials
- Relative humidity
- Rate of change or separation

Table 4 lists an approximation of ESD levels based on various personnel activities and humidity levels.

Table 4
Static charge levels and relative humidity

| Personnel Activity ¹ | Humidity ² & charge levels (volts ³) | | | |
|--|---|----------|----------|----------|
| | 26% | 32% | 40% | 50% |
| Person walking across linoleum floor | 6,150 V | 5,750 V | 4,625 V | 3,700 V |
| Person walking across carpet | 18,450 V | 17,250 V | 13,875 V | 11,100 V |
| Person getting up from a plastic chair | 24,600 V | 23,000 V | 18,500 V | 14,800 V |

¹Source: B. A. Unger, *Electrostatic Discharge Failures of Semiconductor Devices* (Bell Laboratories, 1981).

²A high rate of air flow produces higher static charges than a low air-flow rate, for the same relative humidity level.

³Some data in this table has been extrapolated.

Inspection for damage

All shipping containers have been specially designed to protect their contents under normal shipping conditions. Carefully inspect each carton for signs of shipping damages as it is unpacked. If damage is found after visual inspection, document the damage with photographs and contact the transport carrier immediately.

Unpacking

The customer's bill of material lists all equipment shipped from CONVEX. It should be used as a checklist to ensure that all equipment has arrived.

The procedure for unpacking the shipping container follows:

- Step 1** Unpack each item from its shipping container.
- Step 2** Inspect each item for signs of shipping damage.
- Step 3** If equipment damage is found, document and proceed to the next section.

Note

Save all packing material until after operational checkout of the equipment. This enables equipment to be returned safely to CONVEX, if required.

Damage claims

If any of the equipment was damaged in shipment, a damage claim must be completed by the customer and given to the shipping representative. Obtain claim forms from the shipping representative.

Preinstallation

This section gives steps to be done before installing the ESDI disk system into an existing expansion cabinet or an ESDI drive into an existing ESDI chassis.

Caution

Shut down the system before removing power from the existing expansion cabinet. Failure to do so will cause a system crash and possible loss of data. Refer to *Managing ConvexOS: Operations Guide* for power-down procedures on a CONVEX computer.

- Step 1** Turn the processor's front panel keyswitch to the OFF position. See Figure 3.

Figure 3
Front panel power switch

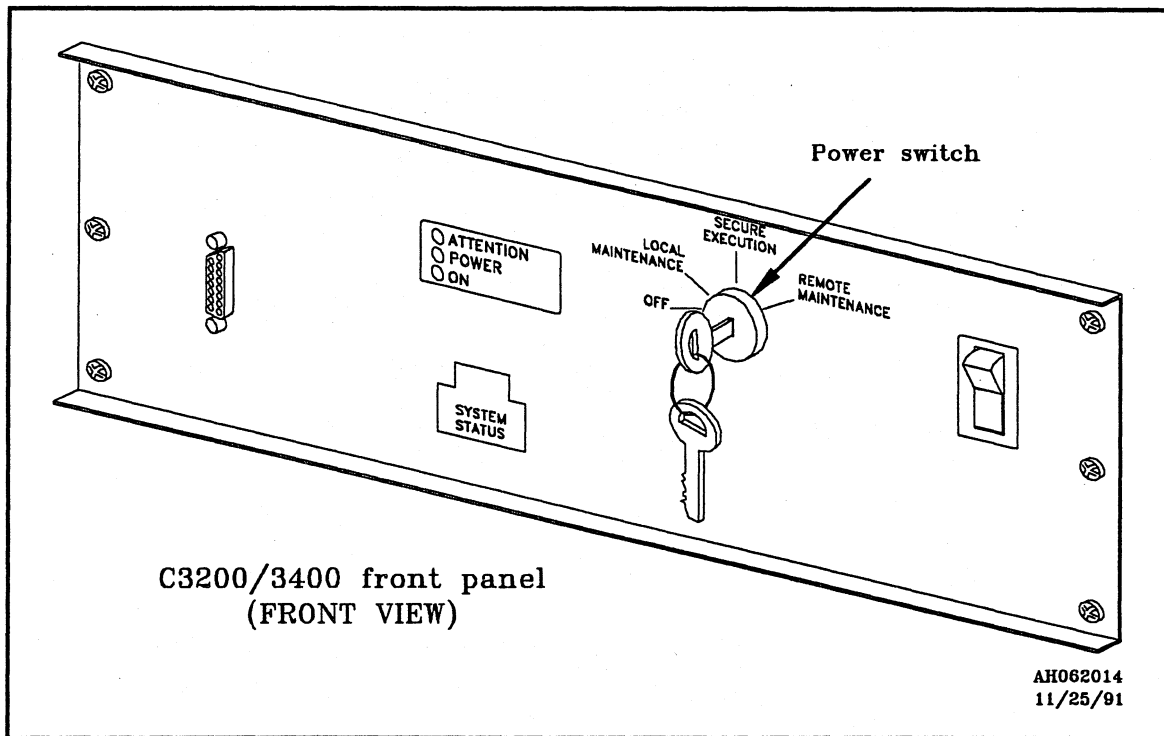

Caution

Remove power to the expansion cabinet before installing or removing equipment. Failure to do so will damage electronic equipment components.

Step 2 Remove power to the expansion cabinet.

- To remove power from a CONVEX EXP-101 or EXP-102 expansion cabinet, disconnect the cabinet's ac power cord.
- To remove power from a CONVEX EXP-105 high-performance expansion cabinet, set the main power control switch to the OFF position. See Figure 4.

Figure 4
EXP-105 power controller

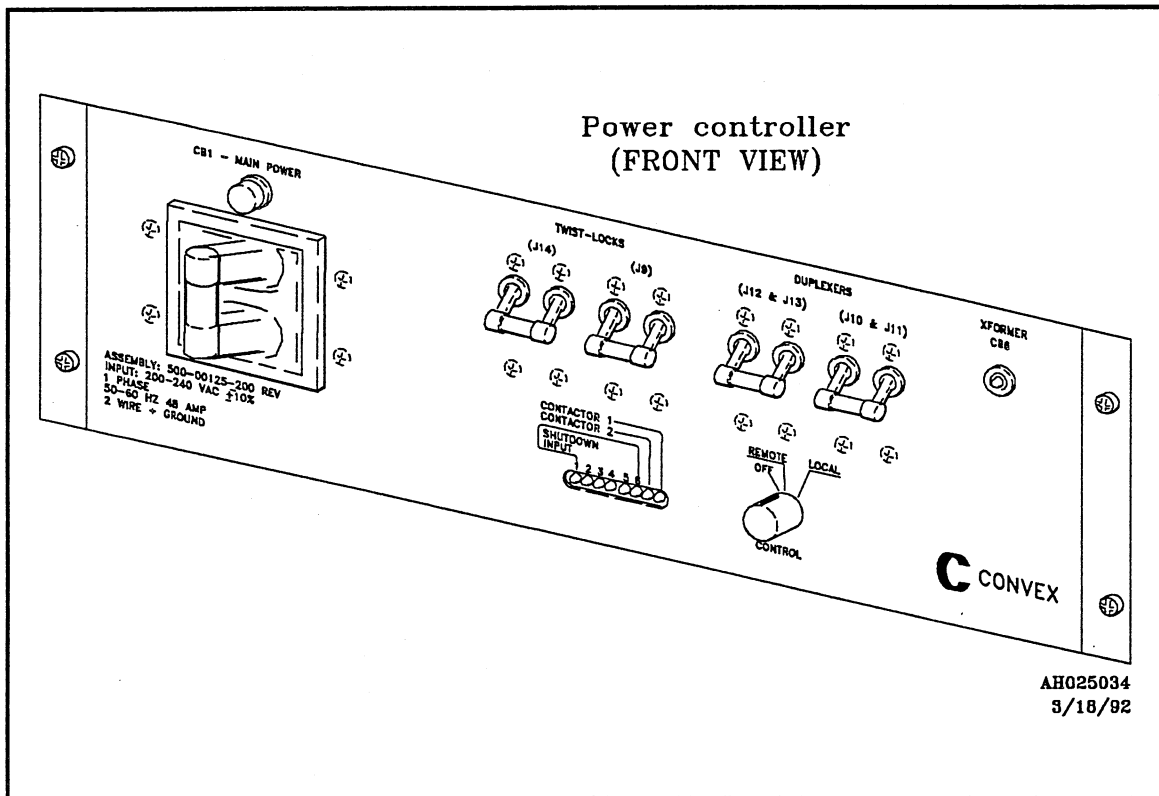

Installation

Step 3 Set the VMEbus chassis power control switch to the OFF position. See Figure 5.

Figure 5
VMEbus chassis power control switch

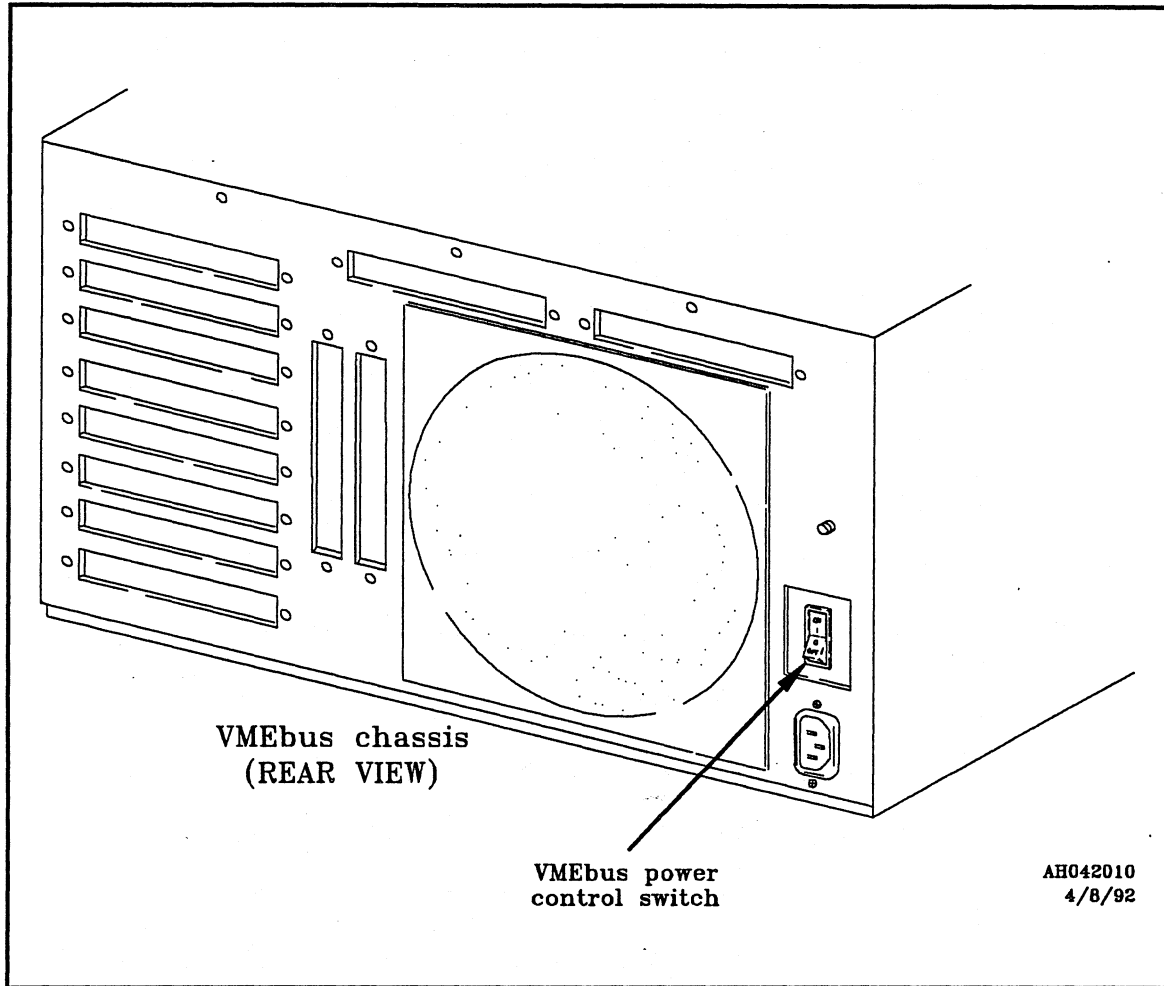

Warning

Expansion cabinet stabilizer bars *must* be extended before installing an ESDI chassis or before extending the ESDI chassis assembly from its expansion cabinet for service. Failure to do so will make the expansion cabinet unstable, increase the possibility of it falling forward, can cause injury to personnel, and will cause damage to equipment.

- Step 4** Extend the expansion cabinet stabilizer bars and adjust the feet until they are in firm contact with the floor. See Figure 6.

Figure 6
Expansion cabinet stabilizer bars

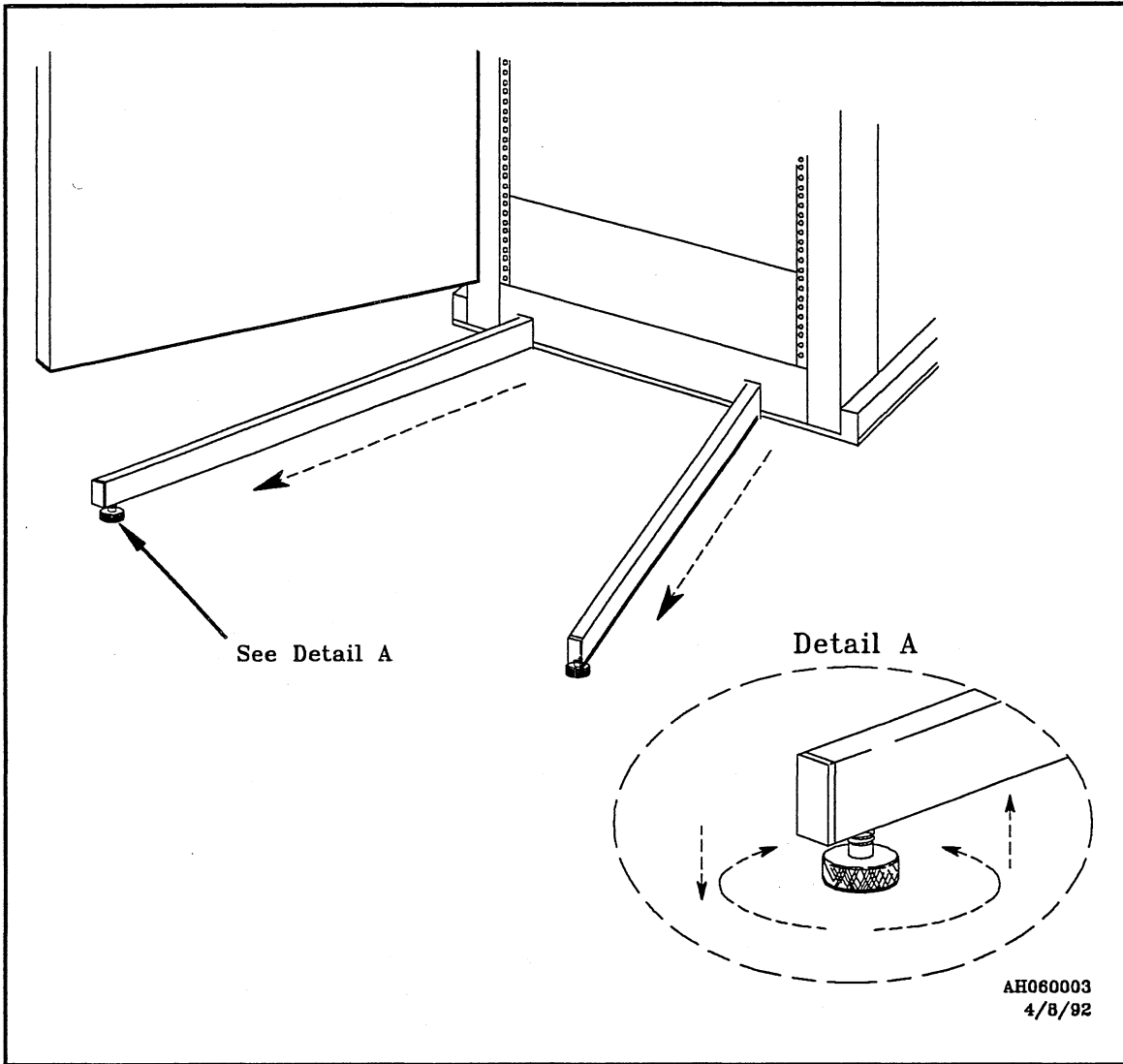

Installation

Installing an ESDI chassis into an expansion cabinet

This section provides procedures for installing an ESDI disk system chassis into an existing CONVEX expansion cabinet. The CONVEX ESDI disk system can be installed in any CONVEX expansion cabinet.

- Step 1** Perform the "Preinstallation procedures" on page 9.

Notes

Refer to the *CONVEX VME/ESDI Disk Controller Service Guide* for more information on installing the VME ESDI disk controller.

The maximum cable length allowed between the VME/ESDI disk controller and the ESDI chassis is approximately 10 ft (3 m).

- Step 2** Install the VME/ESDI disk controller in the VMEbus chassis.
- Step 3** Select a position 7.0 inches in height in the expansion cabinet and remove the blank panels to open the space for the chassis installation.
- Step 4** Install the left and right chassis rails in the selected position in the expansion cabinet, making sure the rails are level front to back and side to side.
- Step 5** Unlock the two captive screws holding the front panel to the ESDI chassis and remove the panel. See Figure 1.
- Step 6** Unlock the 14 captive screws that hold the top panel of the ESDI chassis and remove the panel.
- Step 7** Remove the six screws that hold the I/O panel to the rear of the ESDI chassis and remove the panel. See Figure 7.

Figure 7
ESDI chassis I/O panel

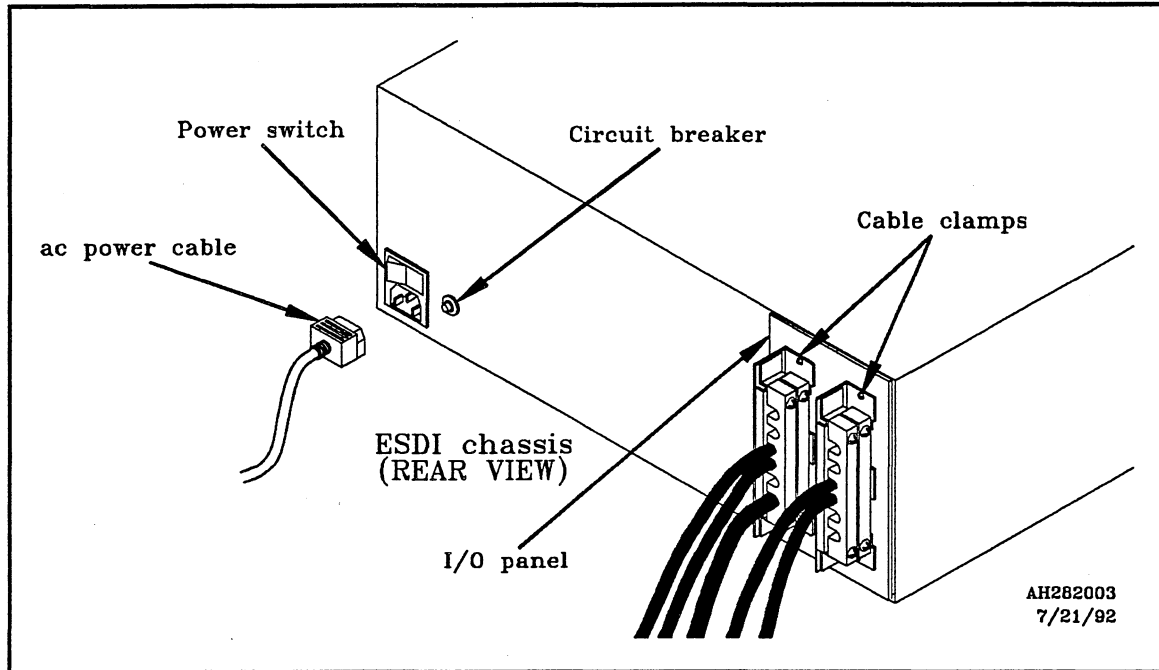

Installation

- Step 8** Loosen and remove if necessary, the two cable clamps on the I/O panel.
- Step 9** Remove the protective sleeve from each ESDI control and data cable to be installed to expose the cable shielding.
- Step 10** Carefully route the ESDI control and data cables through the I/O panel and secure them with the cable clamps. Be sure to clamp the cables across the braided shielding to provide a proper ground connection. Note that the ESDI control cables must be routed through the larger openings in the cable clamp. Data cables may be routed through the smaller openings.

Note

Assemble the innermost cable connector first. This is necessary due to the location of the screws used to tighten the clamp.

- Step 11** Replace the I/O panel and connect each ESDI control cable to the internal control ribbon cable. Figure 8 shows the control cable connection for a single controller with 4 drives.
- Step 12** Connect each ESDI data cable to the appropriate internal data ribbon cable. See Figure 8.

Step 13 Replace the top panel on the ESDI chassis and secure the panel with the 14 captive screws.

Figure 8
ESDI chassis cable connection

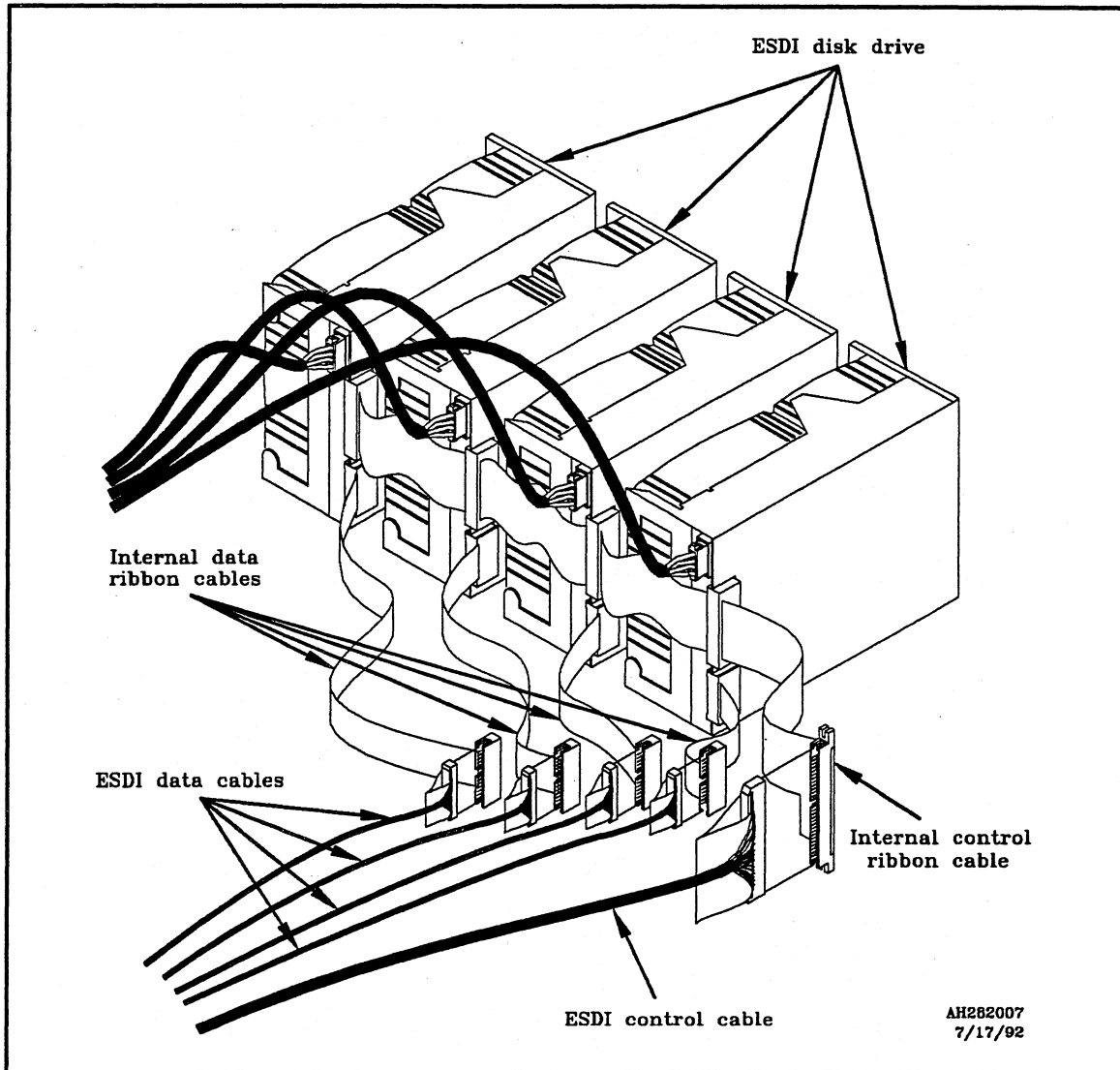

Step 14 Carefully place the ESDI chassis in the rails, feeding the cables through the expansion cabinet so they exit the rear of the cabinet. Push the buttons inward on the side rails and slide the chassis into the expansion cabinet.

Caution

Power *must* be removed from the VMEbus chassis before connecting the VME ESDI disk controller to the ESDI chassis. Failure to do so will cause damage to equipment.

Note

Refer to the *CONVEX VME ESDI Disk Controller Service Guide* and the *Interphase 4201 (ESDI) Disc Controller Configurator* for more information on cabling the VME/ESDI disk controller.

Note

When installing a 1.5-Gbyte ESDI disk drive the VME controller module must be Part No. 220-000025-200 or a later version.

- Step 15** Connect the ESDI control and data cables from the ESDI chassis to the VME/ESDI disk controller in the VMEbus chassis.
- Step 16** Connect the ac power cable to the rear of the ESDI chassis.

Caution

Ensure that the grounding pads are firmly attached to the front panel mounting brackets. Failure to do so may cause ESD damage to components within the ESDI chassis.

- Step 17** Attach the grounding pads, two per bracket, to the front panel mounting brackets. See Figure 9.
- Step 18** Install the two front panel mounting brackets on the first four holes in the front RETMA rail above the ESDI chassis with the screws provided.
- Step 19** Set the ESDI chassis power switch to the ON position.
- Step 20** Position the front panel on the ESDI chassis and secure the two captive screws.
- Step 21** Perform the postinstallation steps listed in "Postinstallation" on page 27.

Figure 9
Front panel mounting bracket

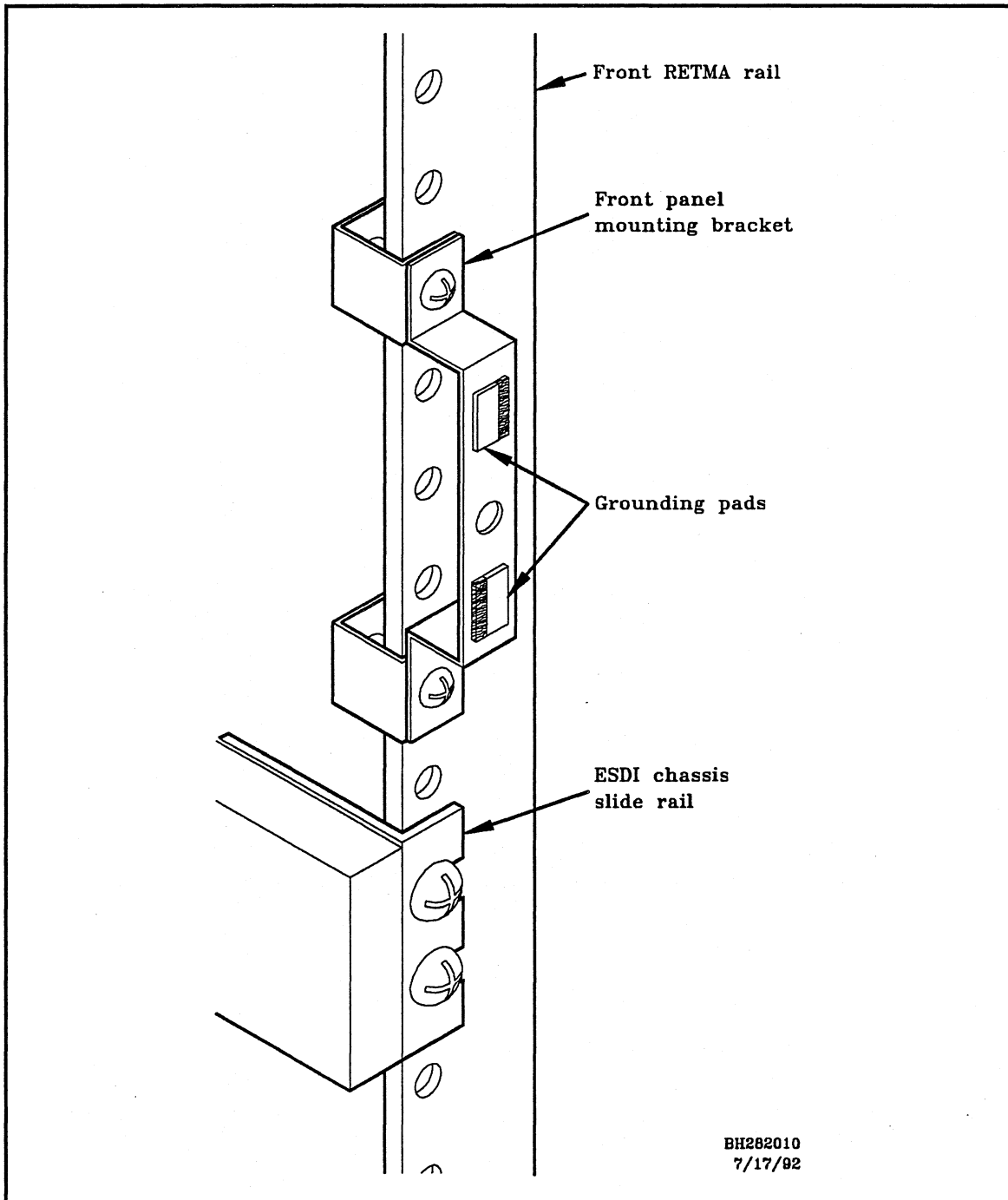

Installing a drive into an ESDI chassis

This section discusses the installation of an ESDI drive into an existing ESDI chassis.

Step 1 Perform the "Preinstallation procedures" on page 9.

Note

If you are installing a second VME ESDI disk controller, refer to the *CONVEX VME ESDI Disk Controller Service Guide* for information on installing the controller.

The maximum cable length allowed between the VME ESDI disk controller and the ESDI chassis is approximately 10 ft (3 m).

Step 2 Set the ESDI chassis power switch to the OFF position. See Figure 10.

Figure 10
ESDI chassis power switch

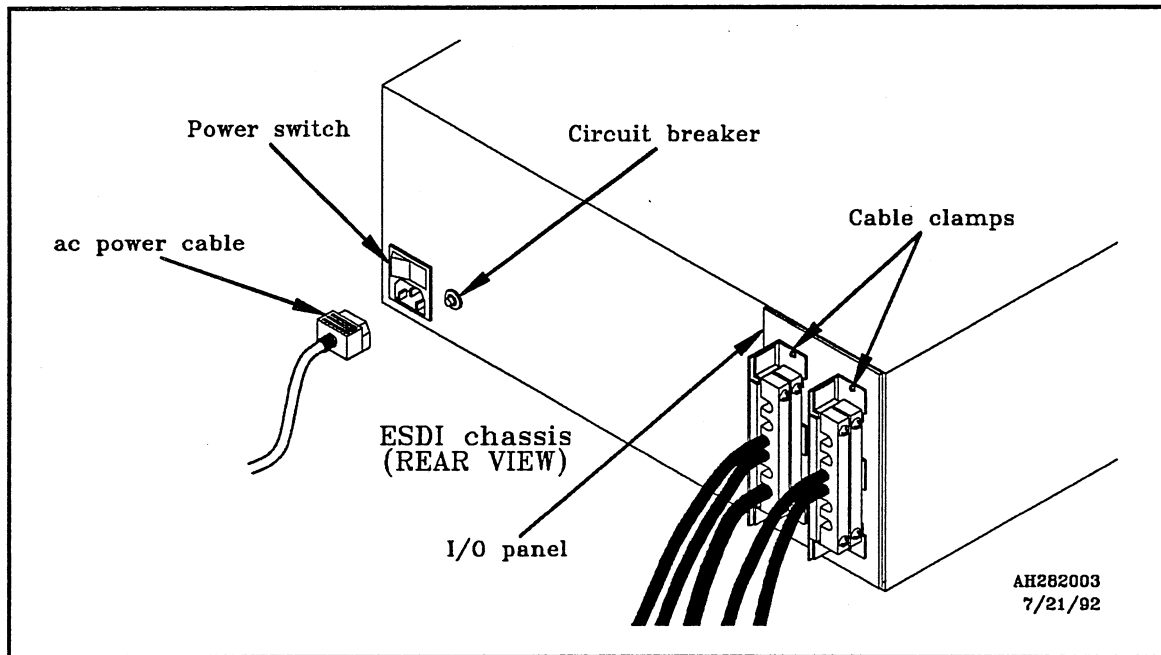

Step 3 Unlock the two captive screws holding the front panel of the ESDI chassis and remove the panel.

Step 4 Remove the two screws holding the ESDI chassis to the front RETMA rails of the expansion cabinet.

Step 5 Pull the ESDI chassis out of the expansion cabinet until the side rails lock into place.

Step 6 Unlock the 14 captive screws that hold the top panel of the ESDI chassis and remove the panel.

If installing a 780-Mbyte drive perform Steps 7 through Step 10. If installing a 1.5-Gbyte drive skip to Step 11.

Note

Refer to the Appendix A *Hitachi 780MB ESDI Disc Drive Configurator* for information concerning device addresses, drive termination and assistance with Step 7 through Step 10 below.

Step 7 Locate and remove the terminator TM223 (see Appendix A) and the three jumpers in jumper block JP224 from the last disk currently installed in the chassis.

Step 8 Remove the jumper from pins 11-12 of jumper block JP282 on the new disk drive. (This selects a 512 byte sector size with 69 sectors per track). And ensure that all other jumpers on JP282 are installed. See Appendix A for the location of jumper block JP282.

Step 9 Check and, if necessary, change the device address (JP213) of the new disk drive. Each disk must have a unique address. See Appendix A for the location of jumper block JP213.

Step 10 Check for, and, if necessary add, the terminator TM223 and the three jumpers in jumper block JP224 on the new disk drive. Go to Step 16.

Perform Steps 11 through 15 when installing a 1.5-Gbyte drive in an ESDI chassis.

NOTE

Refer to Appendix B, *Micropolis 1.53 G-byte ESDI Disc Drive Configurator Document*, for detailed information concerning device addresses, termination, and assistance with Step 11 through Step 15.

Step 11 Locate and remove terminator RN11.

Step 12 Ensure that jumpers W2, W3 and W4 are installed on the device electronics board as described in the configurator. These jumpers set the drive for 597 bytes per sector (see Appendix B).

Step 13 Using jumpers DA1, DA2 and DA3 set the device address. Each disk must have a unique address.

- Step 14** Install the interface terminator on the last drive in the daisy-chain.
- Step 15** Install the remaining jumpers as indicated in Appendix B and go to Step 16.
- Step 16** Position the disk bracket on the ESDI drive and install the two screws (C in Figure 11) that hold the bracket to the drive.

Figure 11
ESDI disk drive position in ESDI chassis

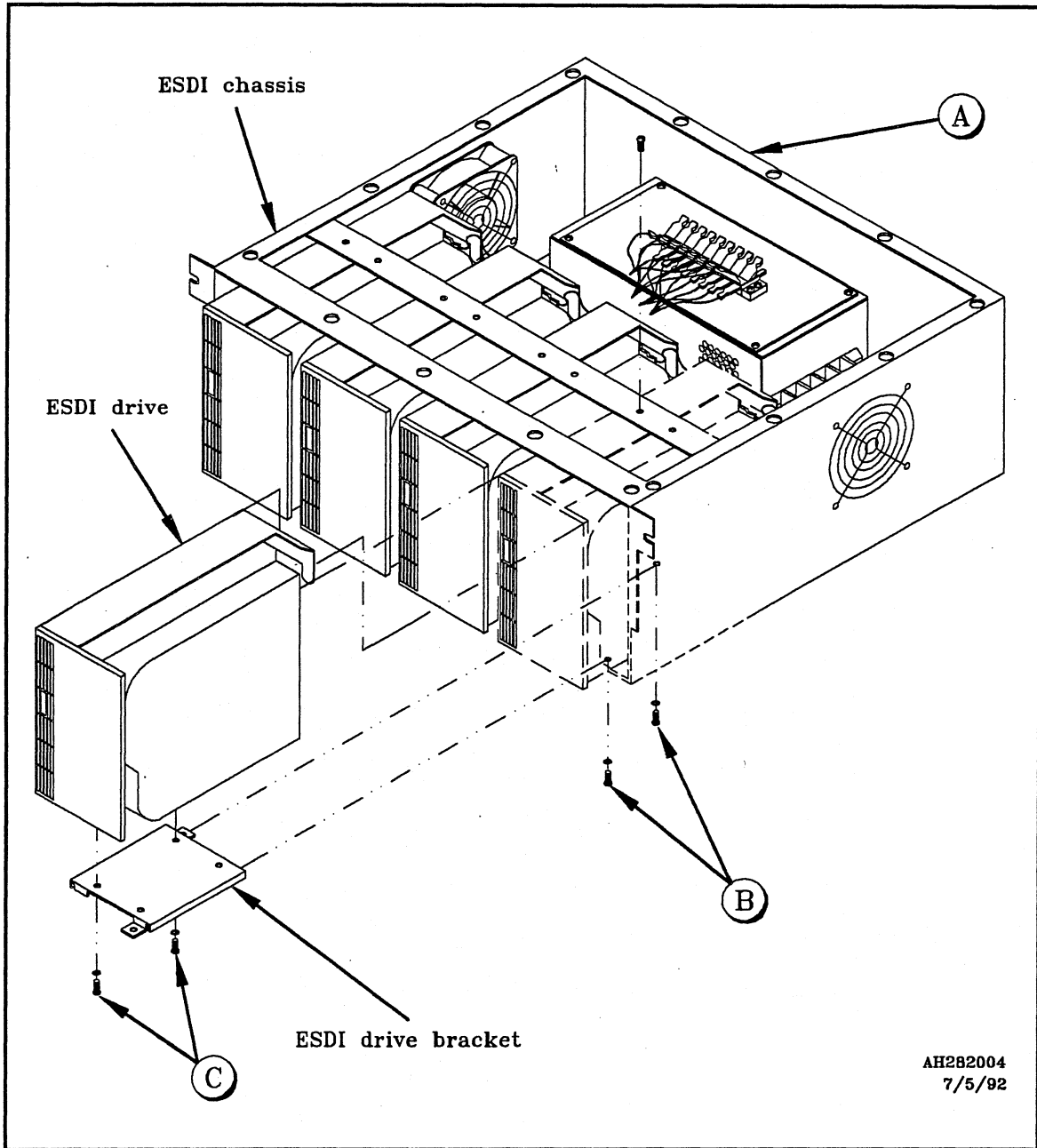

Step 17 Secure the green grounding wire to one of the two screw posts located in the bottom of the chassis between the disks and the 12-volt power supply.

- Step 18** Position the ESDI drive in the selected slot of the ESDI chassis.
- Step 19** Connect the ESDI data ribbon cable to connector J2 on the back of the ESDI drive. See Figure 13.
- Step 20** Connect the ESDI control ribbon cable to connector J1 on the back of the ESDI drive. See Figure 12 for a single controller configuration and Figure 13 for two controller configuration.
- Step 21** Connect the disk drive power cable (already installed), from the power supply barrier strip, to connector J3 on the back of the ESDI drive.
- Step 22** Attach the other end of the green grounding wire to the small ground connector on the rear of the drive (see detail in Figure 12). Be sure that the connector is pushed fully onto the pin.
- Step 23** Install the two screws (B in Figure 11) that hold the ESDI drive to the bottom of the ESDI chassis.
- Step 24** Install the screw (A in Figure 11) that holds the ESDI drive to the top of the ESDI chassis.

Figure 12
Cable connections (4 drives/controller)

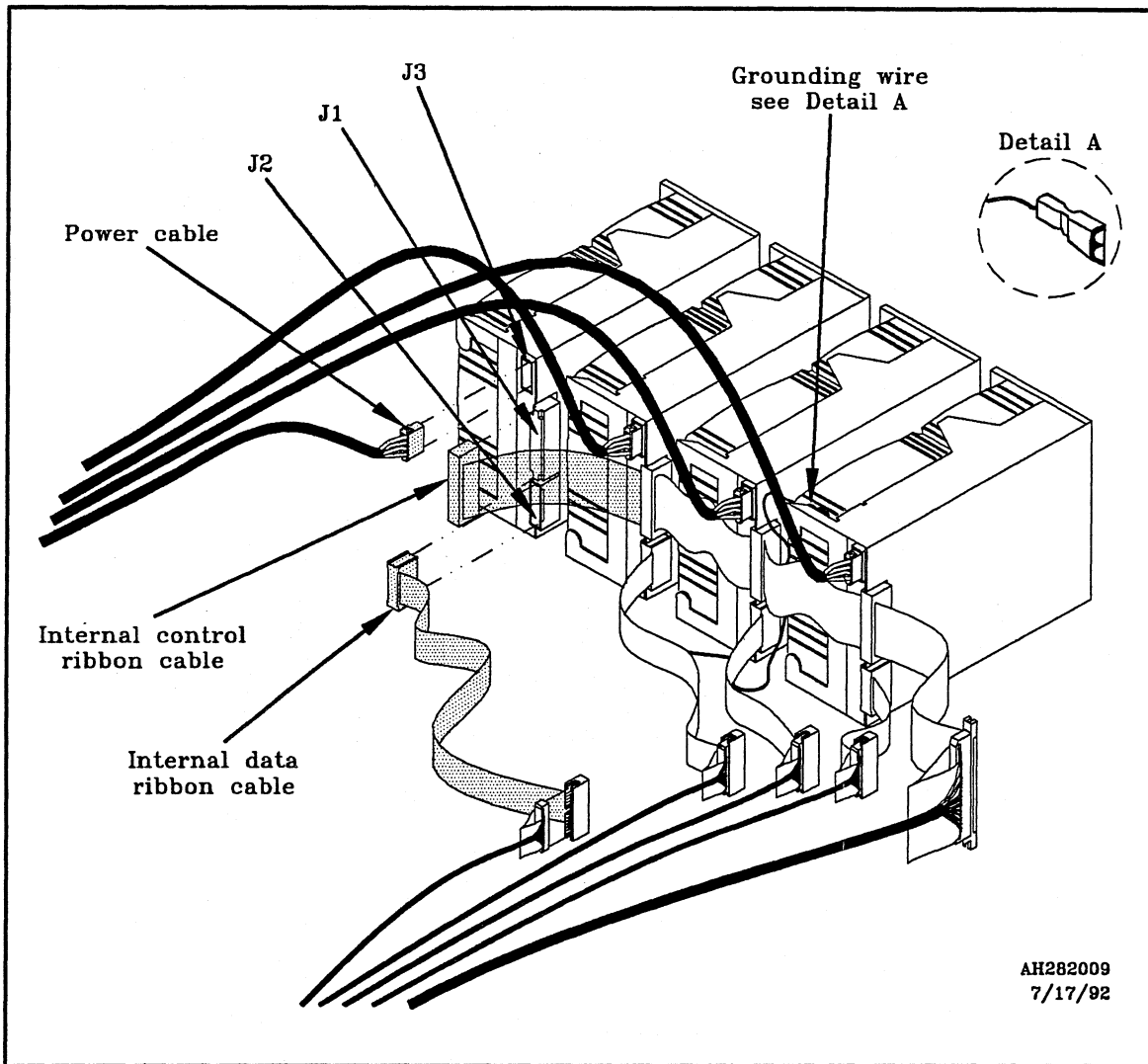
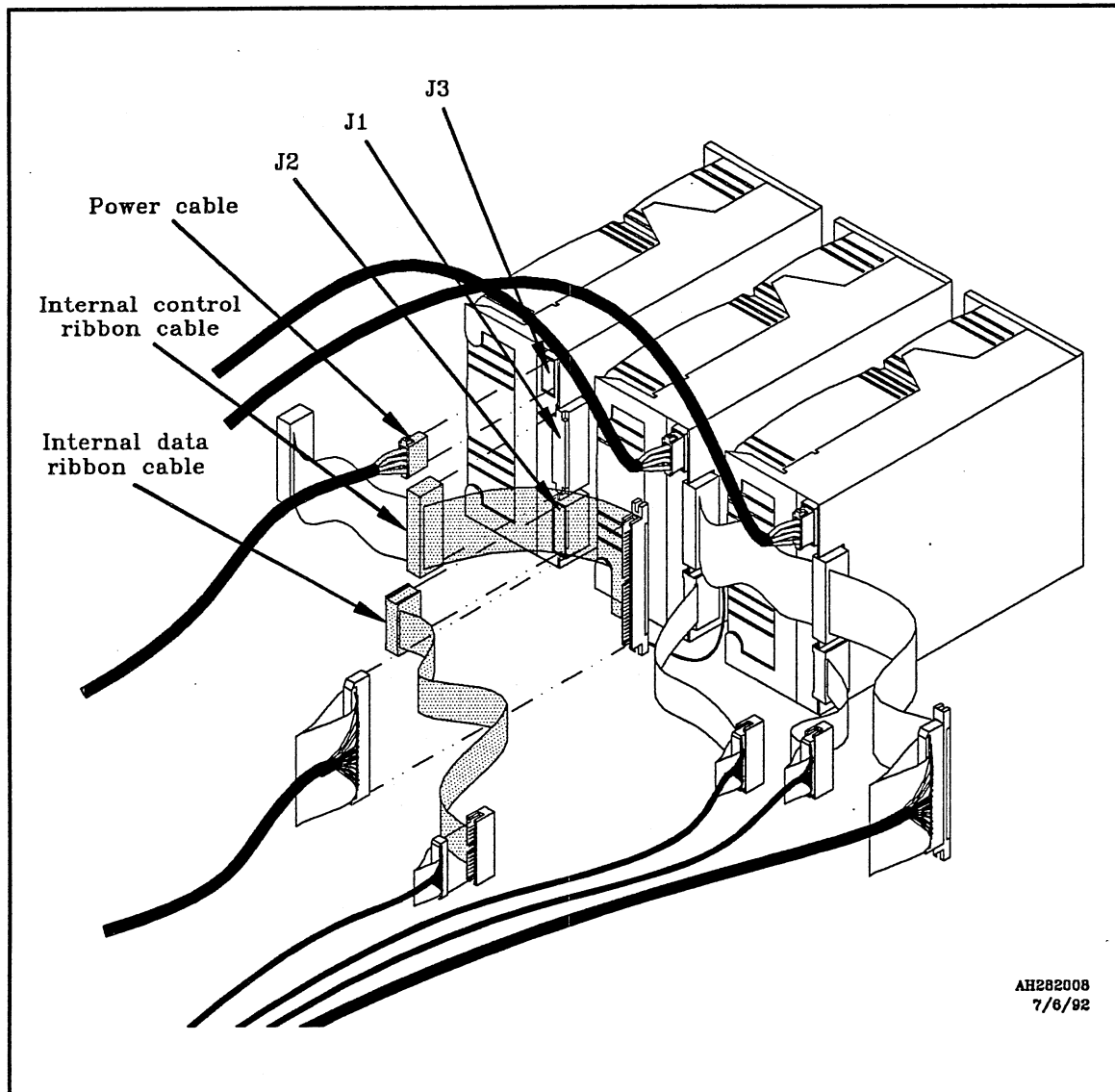

Figure 13
Cable connections (2 drives/controller)



Installation

- Step 25** Loosen, or remove if necessary, one or both cable clamps on the I/O panel.
- Step 26** Remove the protective sleeve from the VME data cable to be installed to expose the braided shielding.
- Step 27** Carefully route the ESDI data cable through the I/O panel and secure the cable with the cable clamp. Be sure to clamp the cable across the braided shielding to ensure a proper ground connection.

- Step 28** If the disk drive requires an additional VME/ESDI disk controller, route the additional ESDI control cable through the I/O panel, remove the protective sleeve, and secure the cable clamp across the braided shielding. Note that ESDI control cables must be routed through the larger openings in the cable clamp.
- Step 29** Replace the I/O panel and connect the ESDI data cable to the internal data ribbon cable as shown in Figure 12.
- Step 30** If necessary, connect the ESDI control cable to the appropriate internal control ribbon cable.
- Step 31** Replace the top panel on the ESDI chassis and secure the panel with the 14 captive screws.

Caution

Power *must* be removed from the VMEbus chassis before connecting the VME/ESDI disk controller to the ESDI chassis. Failure to do so will cause damage to equipment.

Note

Refer to the *CONVEX VME ESDI Disk Controller Service Guide* and the *Interphase 4201 (ESDI) Disc Controller Configurator* for more information on installing and cabling the VME/ESDI disk controller.

- Step 32** Connect the new ESDI data cable from the ESDI chassis to the VME/ESDI disk controller in the VMEbus chassis.
- Step 33** If necessary, connect the new ESDI control cable from the ESDI chassis to the new VME/ESDI disk controller in the VMEbus chassis.
- Step 34** Set the ESDI chassis power switch to the ON position. See Figure 10.
- Step 35** Push the buttons inward on the side rails and slide the ESDI chassis back to its retracted position.
- Step 36** Remove appropriate insert from the ESDI front panel.
- Step 37** Install the two screws that hold the ESDI chassis in the expansion cabinet.
- Step 38** Position the front panel on the ESDI chassis and secure the two captive screws. See Figure 1.
- Step 39** Perform the "Postinstallation procedures" on page 27.

Postinstallation

This section lists steps to be done after an ESDI system installation.

- Step 1** Return the expansion cabinet stabilizer bars to their retracted position. See Figure 6.
- Step 2** Apply power to the VMEbus chassis. See Figure 5.
- Step 3** Apply power to the expansion cabinet:
- To apply power to a CONVEX EXP-101 or EXP-102 expansion cabinet, connect the ac power cord to the site source.
 - To apply power to a CONVEX EXP-105 high-performance expansion cabinet, set the main power control switch to the ON position.
- Step 4** Turn the processor's front panel keyswitch to the LOCAL MAINTENANCE or SECURE EXECUTION position. See Figure 14.

Figure 14
Front panel power switch

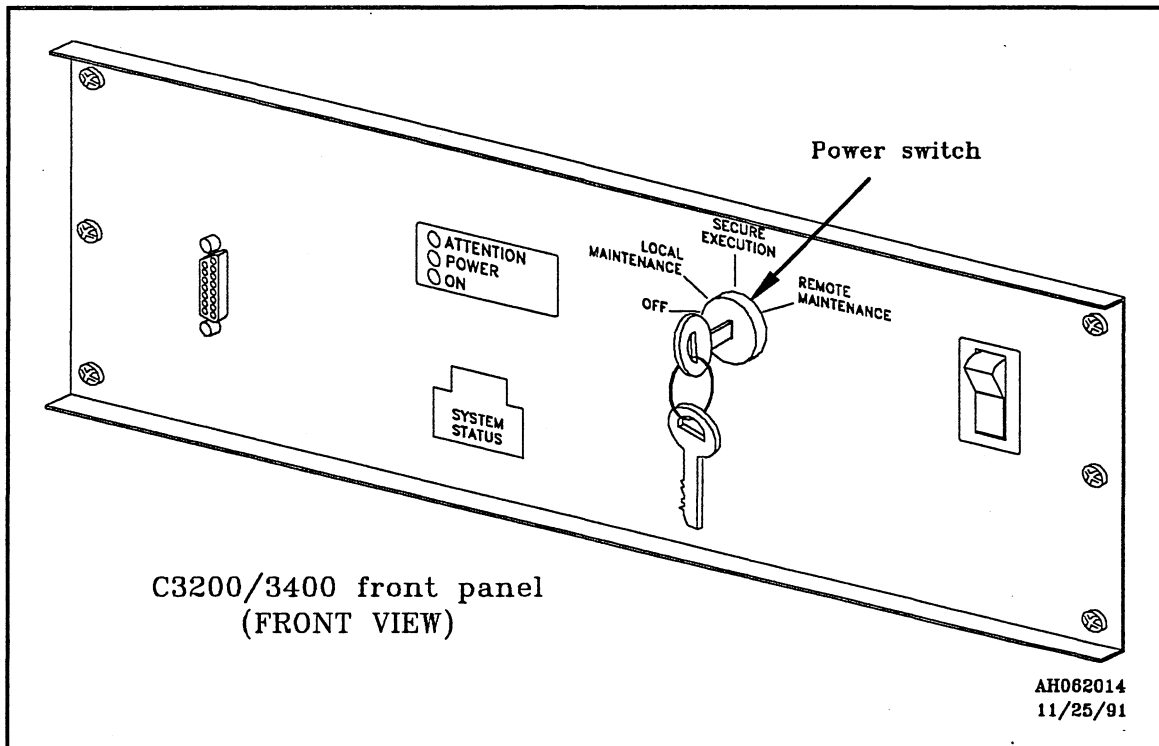

Integration and test

3

Overview

The CONVEX ESDI disk system must be integrated into the CONVEX operating system (ConvexOS) before it can be used. This chapter contains guidelines for integrating an ESDI drive into ConvexOS as well as information on the CONVEX diagnostic tests for the ESDI disk system.

Notes

ConvexOS V8.1 or greater is required to operate a CONVEX 780-Mbyte ESDI disk system. ConvexOS V10.1 or higher is required to operate a CONVEX 1.5-Gbyte disk system. The CONVEX ESDI disk system can be configured with one or two VME ESDI disk controllers: CONVEX systems running ConvexOS V8.1, V9.0 and V9.1 can support a maximum of two disk drives per controller. CONVEX systems running ConvexOS V10.0 and greater can support up to four disk drives per controller without a system generation. Refer to Chapter 3, "Integration and test," for more information.

Software integration

The software for the CONVEX ESDI disk system is released separately from ConvexOS and utilities. Refer to *Managing ConvexOS: Configuration Guide* for additional software integration information. That document includes a complete description of the software integration procedures for ESDI disk drive system software.

System-level hardware is identified to ConvexOS via a configuration file (/ioconfig) located on the service processor unit (SPU) disk. The /ioconfig file describes, in hierarchical fashion, the connections between VIOPs, VMEbus chassis number, controller type, control and status register (CSR) address, interrupt number, and peripheral device type. The device codes for the ESDI disk system are:

- DKC-203 VME ESDI disk controller
- DKD-284 ESDI disk drive (780 Mbyte)
- DKD-287 ESDI disk drive (1.53 Gbyte)

The marketing numbers for the ESDI disk system are :

- DKD-210 780-Mbyte add-on disk
- DKD-310 780-Mbyte disk with VME ESDI disk controller
- DKD-310c 780-Mbyte disk with VME ESDI controller and ESDI chassis
- DKD-211 1.53-Gbyte add-on disk
- DKD-311 1.53-Gbyte disk with VME ESDI disk controller
- DKD-311c 1.53-Gbyte disk with VME ESDI controller and ESDI chassis

Figure 15 shows a typical /ioconfig file with ESDI disk system and VME/ESDI disk controller specific items in **bold** type.

Figure 15
Example /ioconfig file

```
iop 3
  mbus 0
    ctrl LAN-001 csr 0x4c0 int 1
      unit 0 type ex
    ctrl DKC-001 csr 0x3f0 int 2
      unit 0 type DKD-005
    ctrl MTC-001 csr 0x0c0 int 4
      unit 0 type MTD-001
    ctrl ACM-001 csr 0x3c0 int 7
      unit 0 type TTY
      unit 1 type TTY
      unit 2 type TTY
      unit 3 type TTY
      unit 4 type TTY
viop 4
  vme 0
    ctrl DKC-203 csr 0xc00 int 3
      unit 0 type DKD-284
      unit 1 type DKD-284
      unit 2 type DKD-287
      unit 3 type DKD-287
```

Whenever ESDI drives are added or removed, the information in the hardware section of the configuration file (/ioconfig) must be changed, otherwise system operation problems will occur. Refer to *Managing ConvexOS: Configuration Guide* when making these changes.

Testing the ESDI disk system

The CONVEX ESDI disk system is tested by the dev5130 diagnostic program. This program verifies the operation of the ESDI disk system. The dev5130 diagnostic program verifies the following:

- Functional ability of the VME ESDI disk controller to operate in the CONVEX VMEbus I/O environment, including main memory access and interrupt generation and detection
- Mechanical and electrical integrity of the disk drives

In addition, the dev5130 diagnostic program performs the following functions:

- Formats new disk drives and verifies previously formatted drives
- Disk maintenance such as slipping of bad sectors and mapping bad tracks to alternate tracks

The dev5130 diagnostic program is an offline program that must be executed on the SPU while the CPU is halted. The procedures for executing this test are beyond the scope of this manual. This information is contained in the *CONVEX VMEbus SMD/ESDI Disk and Formatter (dev5130) Diagnostics Manual*. Consult that manual before running CONVEX diagnostics.

Notes

For dev5130 release 7.0 is required to support 4 disk drives from a single VME ESDI disk controller.

For dev5130 release 7.03 is required to support 1.5-Gbyte disk systems.

Convex I/O Diagnostics V1.1 is required for C2, C3200, and C3400 Series products.

Convex C Series systems diagnostics V6.6.1 is required for C1 products.

Convex C3800 system diagnostics V2.1 is required for C3800 products.

Maintenance procedures and IPB

4

Overview

This chapter provides removal and replacement procedures and an illustrated parts breakdown (IPB) for the CONVEX ESDI disk system.

Maintenance procedures

This section gives information on removal and replacement procedures for field replaceable units (FRUs) for the ESDI disk system.

Preservice procedures

This section gives procedures that need to be performed before continuing with the removal or replacement procedures.

Caution

Shut down the system before removing power from the existing expansion cabinet. Failure to do so will cause a system crash and possible loss of data. Refer to *Managing ConvexOS: Operations Guide* for power-down procedures on a CONVEX computer.

Caution

Power *must* be removed from the VMEbus chassis before disconnecting and connecting the VME ESDI disk controller to the ESDI chassis. Failure to do so will cause damage to equipment.

- Step 1** Set the VMEbus chassis power control switch to the OFF position. See Figure 16.

Figure 16
VMEbus chassis power control switch

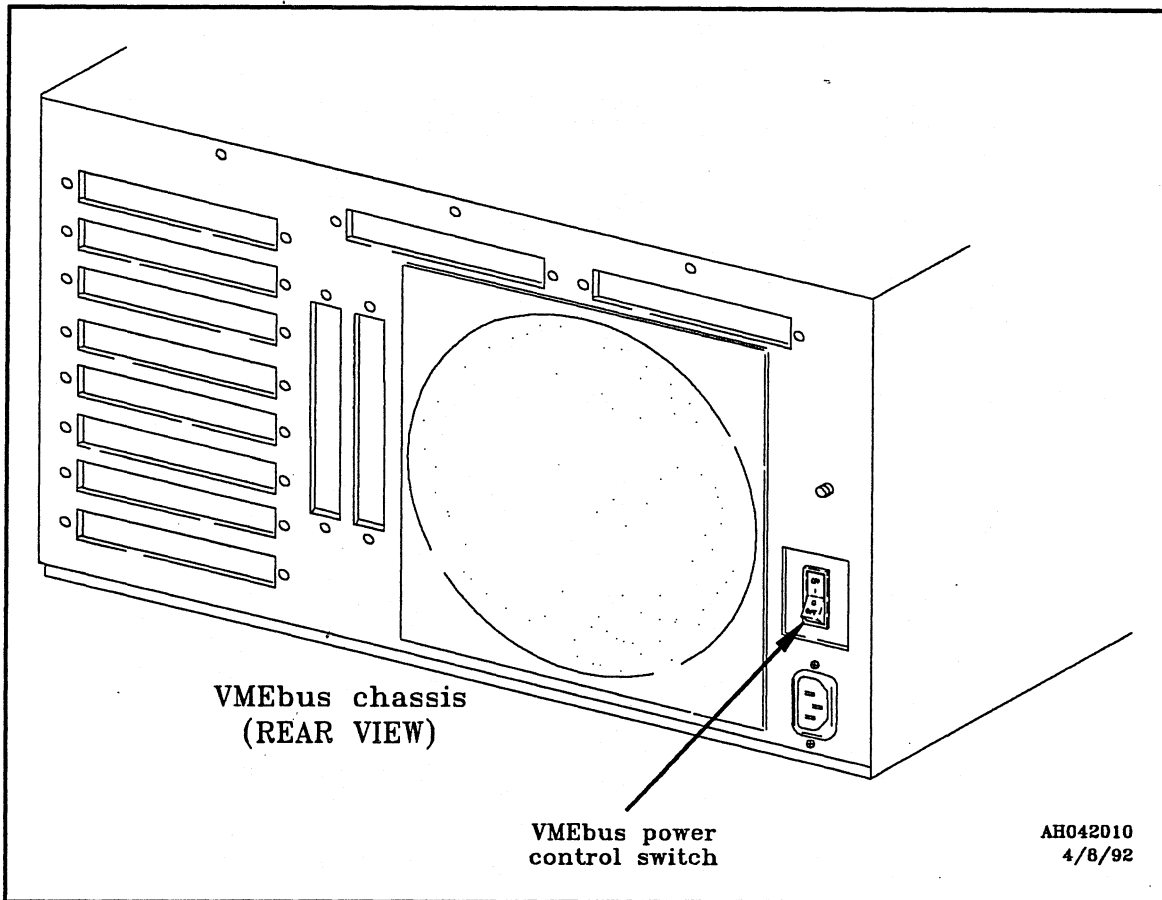

Caution

Remove power to the expansion cabinet before removing or servicing any equipment. Failure to do so will cause damage to electronic equipment components.

Step 2 Remove power to the expansion cabinet.

- To remove power from a CONVEX EXP-101 or EXP-102 expansion cabinet, disconnect the ac power cord from the ac power source.
- To remove power from a CONVEX EXP-105 high-performance expansion cabinet, set the main power control switch to the OFF position.

Warning

Expansion cabinet stabilizer bars must be extended prior to extending any component installed in the expansion cabinet. Failure to do so will make the expansion cabinet unstable, increase the possibility of it falling forward, can cause injury to personnel, and will cause damage to equipment.

- Step 3** Extend the expansion cabinet stabilizer bars and adjust the feet until they are in firm contact with the floor. See Figure 17.

Figure 17
Expansion cabinet stabilizer bars

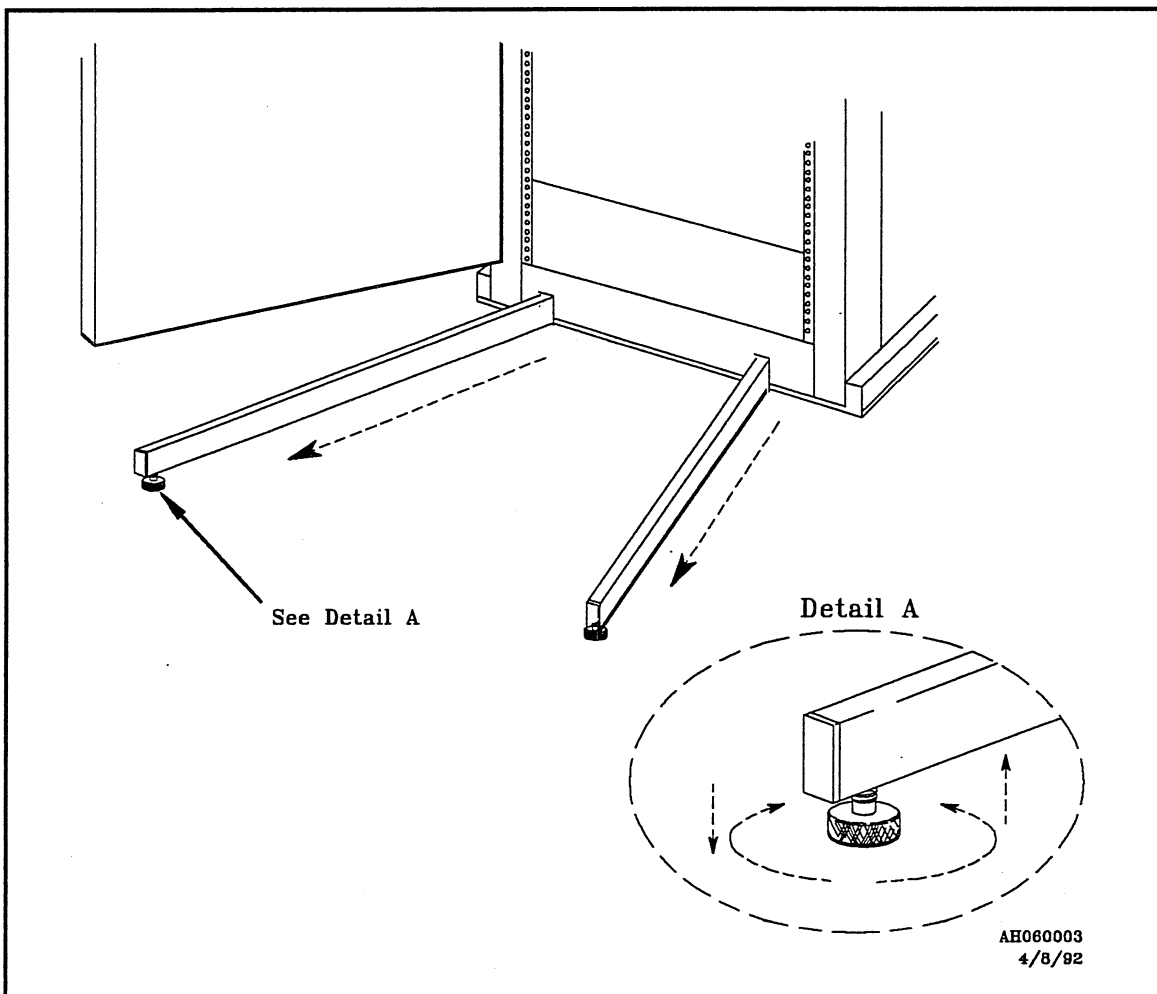

- Step 4** Unlock the two captive screws on the front panel of the ESDI chassis.
- Step 5** Remove the ESDI chassis front panel.

- Step 6** Remove the two screws holding the ESDI chassis in the expansion cabinet.
- Step 7** Slide the ESDI chassis out of the cabinet until the side rails lock into position.
- Step 8** On the back side of the ESDI chassis, set the power switch to the OFF position. See Figure 18.

Figure 18
ESDI chassis power switch

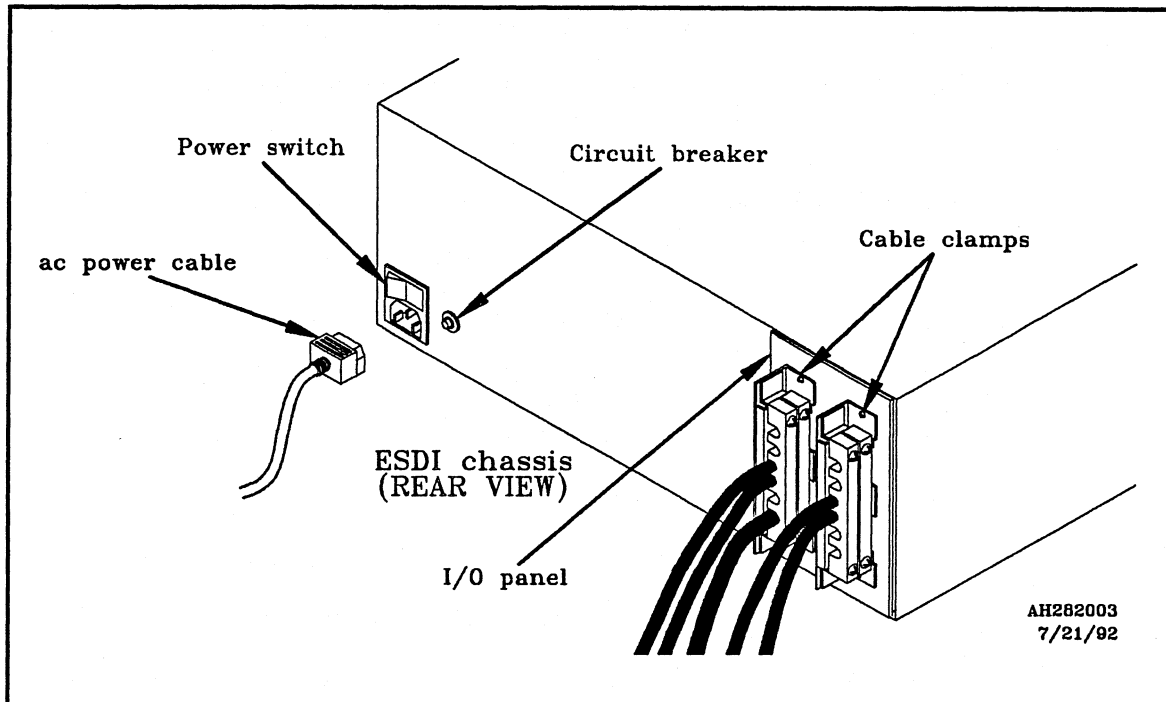

- Step 9** Unlock the 14 captive screws that secure the top of the ESDI chassis and remove the top.

ESDI drive unit removal and replacement

This section gives the procedure for removing and replacing the ESDI drive. See Figure 19.

Figure 19
ESDI disk unit

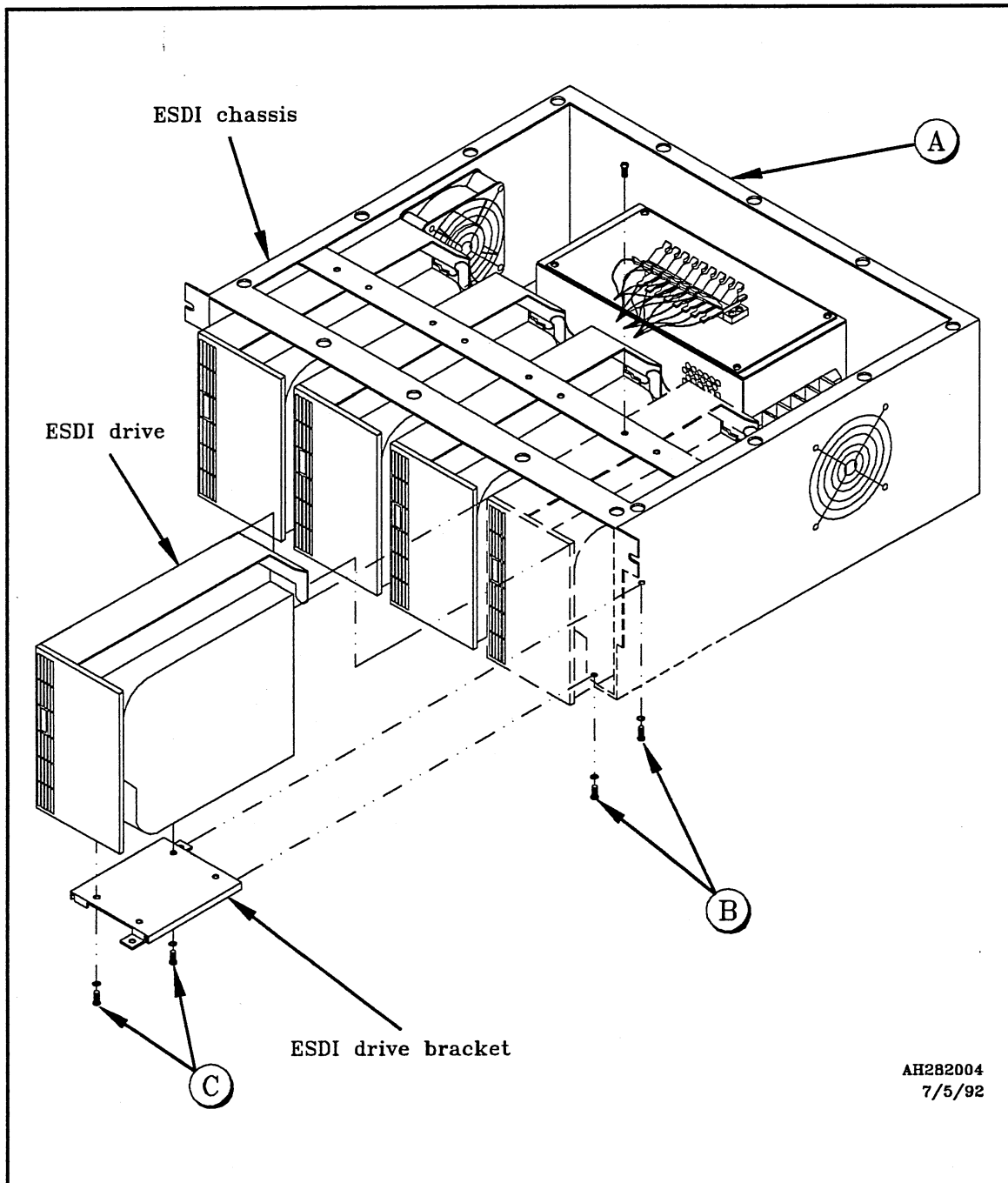

AH282004
7/5/92

Maintenance

Removal

- Step 1** Perform the "Preservice procedures" listed on page 33.
- Step 2** Remove the disk drive power cable from the rear of the ESDI drive.
- Step 3** Remove the two ribbon cables from the rear of the ESDI drive.
- Step 4** Remove the ground wire from the ESDI drive.
- Step 5** Remove the screw (A in Figure 19) holding the ESDI drive to the top of the ESDI chassis.
- Step 6** Remove the two screws (B in Figure 19) holding the ESDI drive bracket to the ESDI chassis.
- Step 7** Remove the ESDI drive.
- Step 8** Remove the two screws (C in Figure 19) holding the bracket to the ESDI drive.

Replacement

- Step 1** Check and, if necessary, change the device address to match the replaced drive. (Refer to Appendix A for details concerning the 780-Mbyte drive and Appendix B for the 1.5-Gbyte drive).
- Step 2** Add or remove terminator TM223 (780-Mbyte drive) or RN11 (1.5-Gbyte drive) and the jumpers in jumper block JP224 (780-Mbyte drive) or multiple jumpers (1.5-Gbyte drive) to match the replaced drive.
- Step 3** Remove the jumper from pins 11-12 of jumper block JP282. (This selects a 512 data byte sector size with 69 sectors per track). Ensure that all other jumpers on JP282 are installed. (780-Mbyte drive only)
- Step 4** Install the two screws (C in Figure 19) that hold the bracket to the ESDI drive.
- Step 5** Position the ESDI drive into the chassis.
- Step 6** Connect the ESDI data ribbon cable to connector J2 on the back of the ESDI drive. See Figure 12.
- Step 7** Connect the ESDI control ribbon cable to connector J1 on the back of the ESDI drive.
- Step 8** Connect the disk drive power cable from the power supply barrier strip to connector J3 on the back of the ESDI drive.
- Step 9** Attach the green grounding wire to the ground connector on the rear of the drive (see detail in Figure 12).

- Step 10** Install the screw (A in Figure 19) that holds the ESDI drive to the top of the ESDI chassis.
- Step 11** Install the 2 screws (B in Figure 19) that hold the ESDI drive bracket to the chassis.
- Step 12** Perform the "Postservice procedures" listed on page 46.

Power supply removal and replacement

This section gives procedures for removing and replacing the 5-volt and 12-volt power supplies. See Figure 20.

Figure 20
ESDI drive power supply

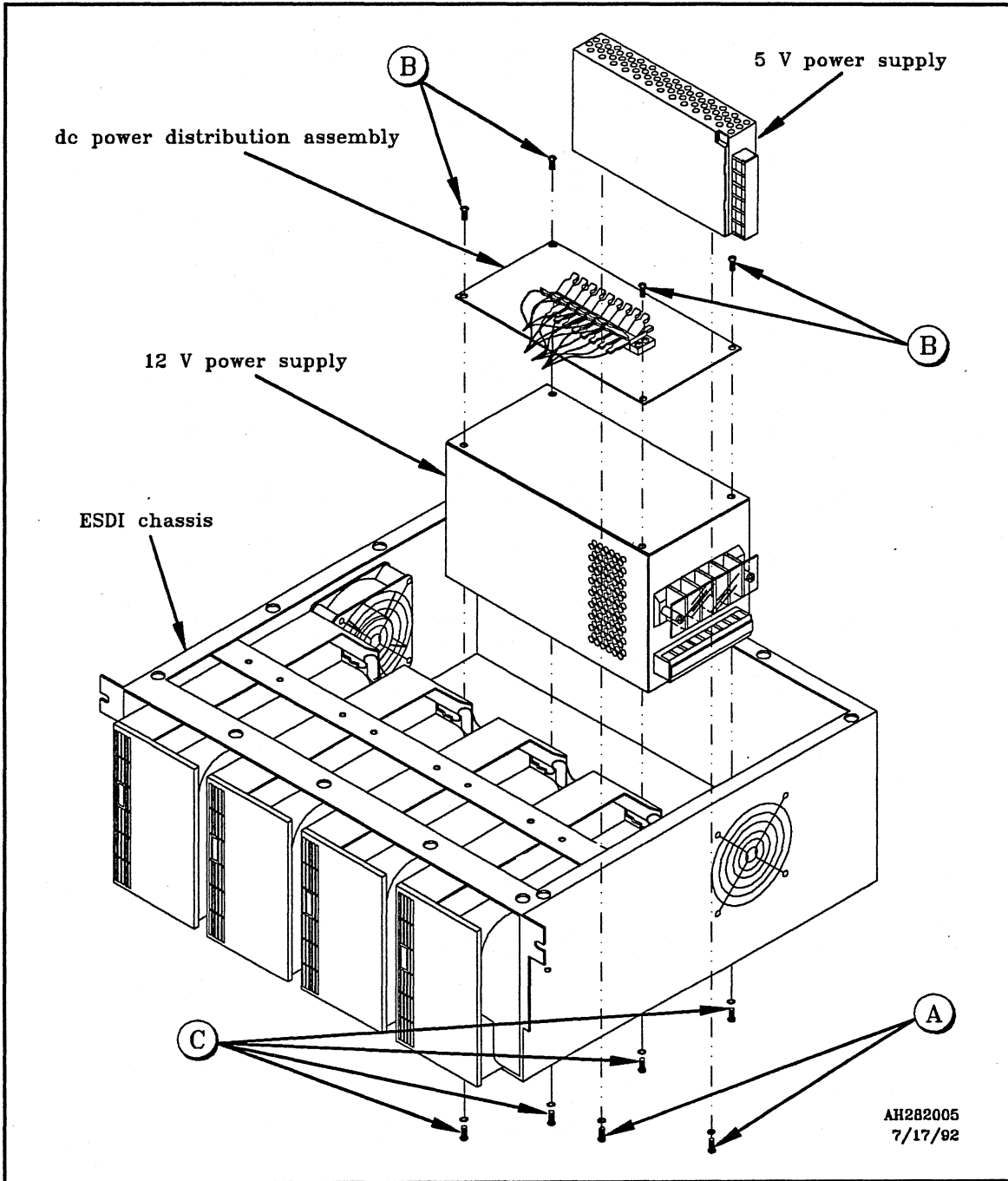

5-volt power supply removal

- Step 1** Perform the "Preservice procedures" listed on page 33.
- Step 2** Remove the two screws (A in Figure 20) connecting the power supply to the bottom of the ESDI chassis.
- Step 3** Mark and disconnect all wires from the power supply.
- Step 4** Remove the power supply from the ESDI chassis.

5-volt power supply replacement

- Step 1** Reconnect all wires to the terminal block on the side of the supply.
- Step 2** Position the power supply in the ESDI chassis.
- Step 3** Install the two screws (A in Figure 20) that hold the power supply to the bottom of the ESDI chassis. *Do not* overtighten the screws.
- Step 4** Perform the postservice procedures listed on page 46.

12-volt power supply removal

- Step 1** Perform the preservice procedures listed on page 33.
- Step 2** Disconnect the power cable from each disk drive.
- Step 3** Uncouple the cable going to the fans.
- Step 4** Remove the four screws (B in Figure 20) that hold the plate containing the terminal block on the top of the power supply. Lay the terminal block assembly over the rear edge of the chassis.
- Step 5** Remove the four screws (C in Figure 20) that hold the power supply to the bottom of the ESDI chassis.
- Step 6** Remove the power supply from the ESDI chassis.
- Step 7** Mark and disconnect all wires connected to the power supply.

12-volt power supply replacement

- Step 1** Reconnect all wires to the terminal block on the side of the power supply.
- Step 2** Position the power supply in the ESDI chassis.
- Step 3** Install the four screws (C in Figure 20) that hold the power supply to the bottom of the ESDI chassis.
- Step 4** Install the plate containing the terminal block to the top of the power supply using the four screws (B in Figure 20).

- Step 5** Reconnect the cable going to the fans.
- Step 6** Reconnect the power cable to each disk drive.
- Step 7** Perform the "Postservice procedures" listed on page 46.

ESDI chassis cooling fan removal and replacement

This section give the procedures for removing and replacing the cooling fans in the ESDI chassis. See Figure 21.

Figure 21
ESDI chassis fan and power control FRUs

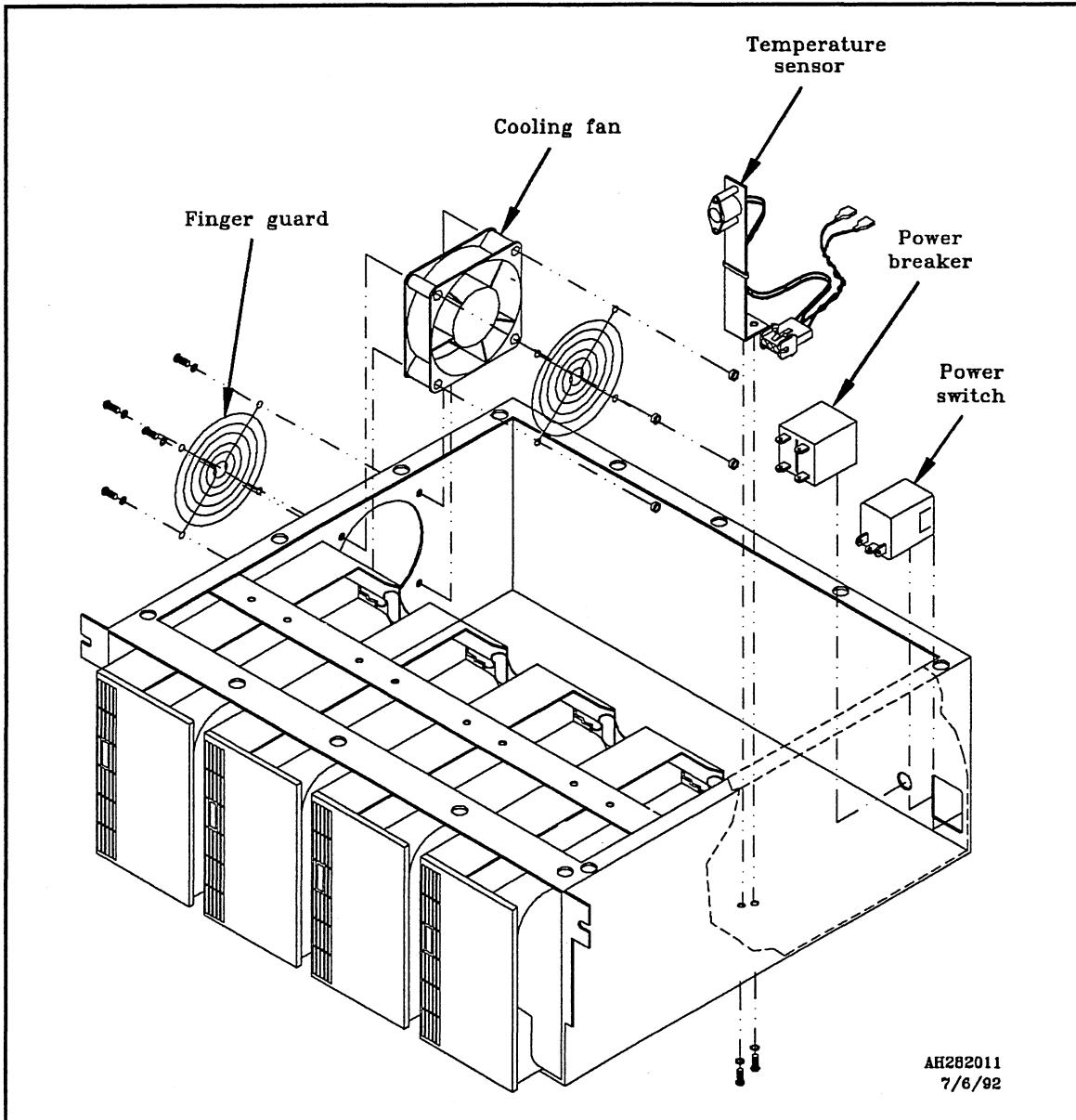

Maintenance

Removal

- Step 1** Perform the "Preservice procedures" listed on page 33.

Caution

Fan nuts are not captive and may be lost within the chassis. This may cause damage to equipment.

- Step 2** Remove the four screws and four nuts attaching the fan to the side of the ESDI chassis.
- Step 3** Disconnect the fan power cable.
- Step 4** Remove the inner and outer finger guards.
- Step 5** Remove the fan.

Replacement

- Step 1** Connect the power cable to the fan.
- Step 2** Position the fan to the side of the ESDI chassis.
- Step 3** Position the finger guards, one on each side of the fan.
- Step 4** Install the four screws and four nuts that attach the fan to the ESDI chassis.
- Step 5** Perform the "Postservice procedures" listed on page 46.

ESDI chassis power breaker

This section gives the procedures for removing and replacing the power breaker from the back of the ESDI chassis. See Figure 21.

Removal

- Step 1** Perform the "Preservice procedures" listed on page 33.
- Step 2** Mark the four wires connected to the chassis power breaker.
- Step 3** Disconnect the four wires connected to the chassis power breaker.
- Step 4** Remove the nut holding the breaker to the ESDI chassis rear panel.
- Step 5** Remove the chassis power breaker.

Replacement

- Step 1** Position the chassis power breaker in the hole in the rear panel of the ESDI chassis.
- Step 2** Install the nut that holds the breaker to the rear panel of the ESDI chassis.
- Step 3** Connect the four wires to the chassis power breaker.
- Step 4** Perform the "Postservice procedures" listed on page 46.

ESDI chassis power switch removal and replacement

This section gives the procedures for removing and replacing the ESDI chassis power switch. See Figure 21.

Removal

- Step 1** Perform the "Preservice procedures" listed on page 33.
- Step 2** Remove the ESDI chassis power breaker.
- Step 3** Mark the three wires connected to the ESDI chassis power switch.
- Step 4** Disconnect the three wires connected to the power switch.
- Step 5** Press the stop tabs on each side of the power switch inward. This may be difficult due to the closeness of the switch to the chassis side. As an alternative remove the circuit breaker located next to the switch and twist the switch as you depress the tab on the exposed side.
- Step 6** Push and remove the power switch out the rear of the ESDI chassis.

Replacement

- Step 1** Press the power switch in the rear of the ESDI chassis until the stop tabs lock into place.
- Step 2** Connect the 3 wires to the ESDI chassis power switch.
- Step 3** Install the ESDI chassis power breaker.
- Step 4** Perform the "Postservice procedures" listed on page 46.

ESDI chassis temperature sensor

This section gives the procedures to remove and replace the ESDI chassis temperature sensor. See Figure 21.

Removal

- Step 1** Perform the "Preservice procedures" listed on page 33.
- Step 2** Mark the two wires connected to the ESDI chassis power breaker.
- Step 3** Remove the two wires connected to the ESDI chassis power breaker.
- Step 4** Uncouple the temperature sensor cable from the wiring harness.
- Step 5** Remove the two screws that hold the temperature sensor to the bottom of the ESDI chassis.

Replacement

- Step 1** Position the temperature sensor on the bottom of the ESDI chassis.
- Step 2** Install the two screws that hold the temperature sensor to the bottom of the ESDI chassis.
- Step 3** Couple the wiring harness to the temperature sensor coupler.
- Step 4** Connect the two wires to the ESDI chassis power breaker.
- Step 5** Perform the "Postservice procedures" listed on page 46.

Postservice procedures

This section gives procedures that should be performed after any removal or replacement procedures:

- Step 1** Position the top on the ESDI chassis and lock the 14 captive screws in place.
- Step 2** On the back of the ESDI chassis, set the chassis power switch to the ON position. See Figure 18.
- Step 3** Push the buttons in on the side rails and slide the ESDI chassis into the expansion cabinet.
- Step 4** Install the two screws that hold the ESDI chassis in the expansion cabinet.

- Step 5** Position the ESDI chassis front panel on the chassis and lock the two captive screws that secure the panel to the chassis.
- Step 6** Return the expansion cabinet stabilizer bars to their retracted position. See Figure 17.
- Step 7** Set the VMEbus chassis power control switch to the ON position. See Figure 16.
- Step 8** Power up the expansion cabinet.
- To return power to a CONVEX EXP-101 or EXP-102 expansion cabinet, connect the ac power cord to the ac power source.
 - To return power to a CONVEX EXP-105 high-performance expansion cabinet, set the main power control switch to the ON position.

**ESDI chassis and
ESDI drive IPB**

This section supplies an integrated parts breakdown (IPB) for the ESDI chassis, drive, power supplies, and all associated cables.

Table 5
Disk drive list

| Item number | CONVEX part number | Description |
|--------------------|---------------------------|---|
| 1 | 204-000019-200 | 780-Mbyte ESDI disk drive |
| 1 | 204-000025-200 | 1.5-Gbyte ESDI disk drive |
| 2 | 320-001646-500 | Drive bracket |
| 3 | 603-010038-200 | Ground wire |
| 4 | 310-002301-002 | Disk drive bracket screw 6-32 x 1/4 inch |
| 5 | 310-002302-004 | Disk drive bracket screw 6-32 x 3/8 with washer |

Figure 22
ESDI drive IPB

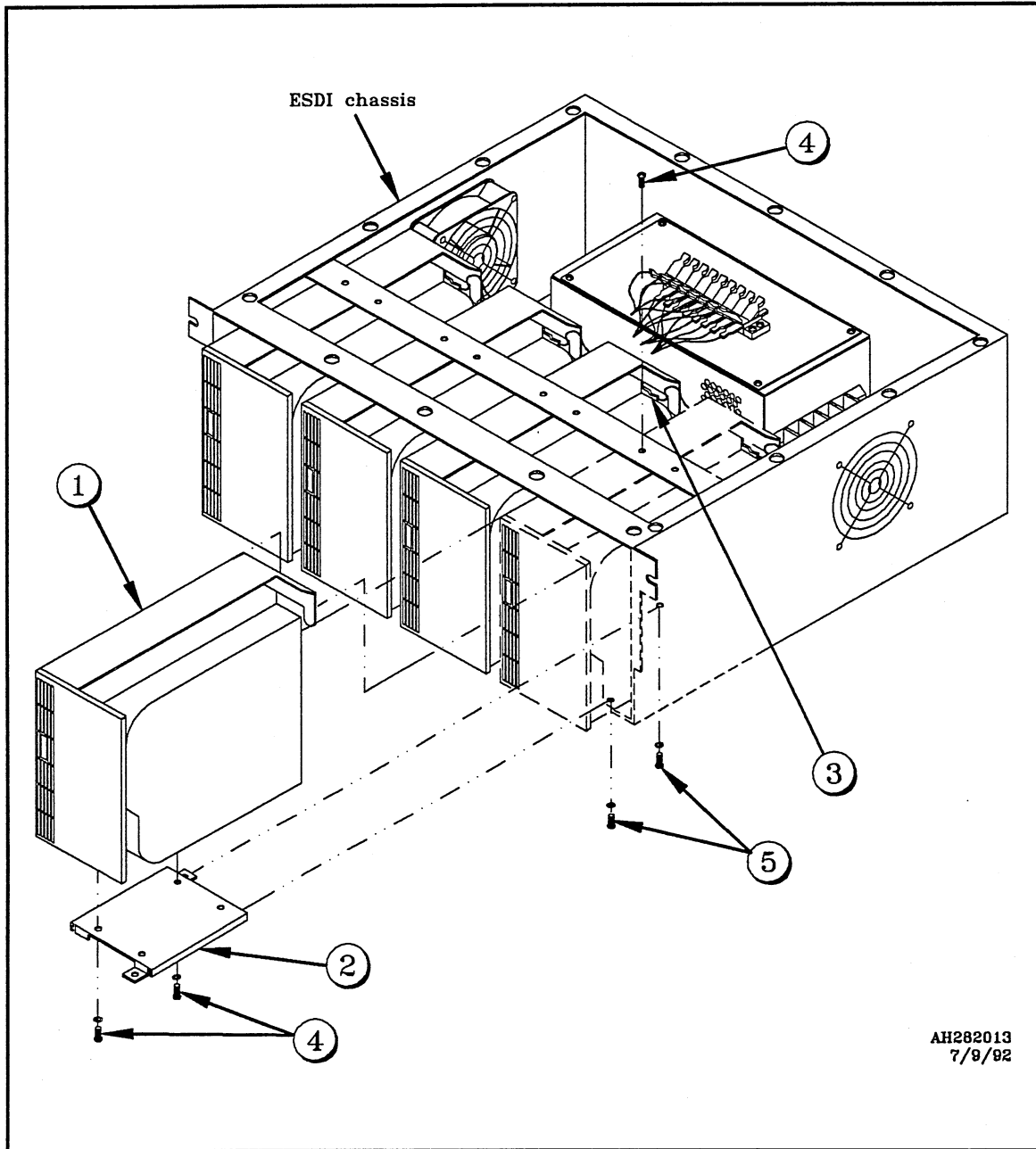

Maintenance

Table 6
Power supply list

| Item number | CONVEX part number | Description |
|--------------------|---------------------------|--|
| 1 | 500-000484-200 | 5-volt power supply subassembly |
| NA | 200-001031-200 | 5-volt power supply |
| NA | 200-001027-001 | 5-volt power supply cover |
| 2 | 200-001038-200 | 12-volt power supply |
| 3 | 500-000512-200 | dc power distribution assembly |
| 4 | 310-000200-003 | 5-volt power supply screw 4-40 x 1/4 inch |
| NA | 310-200210-001 | #4 split lock washer for 4-40 x 1/4 inch screw |
| 5 | 310-002401-002 | 12 volt power supply screw 8-32 x 1/4 inch |

Figure 23
Power supply IPB

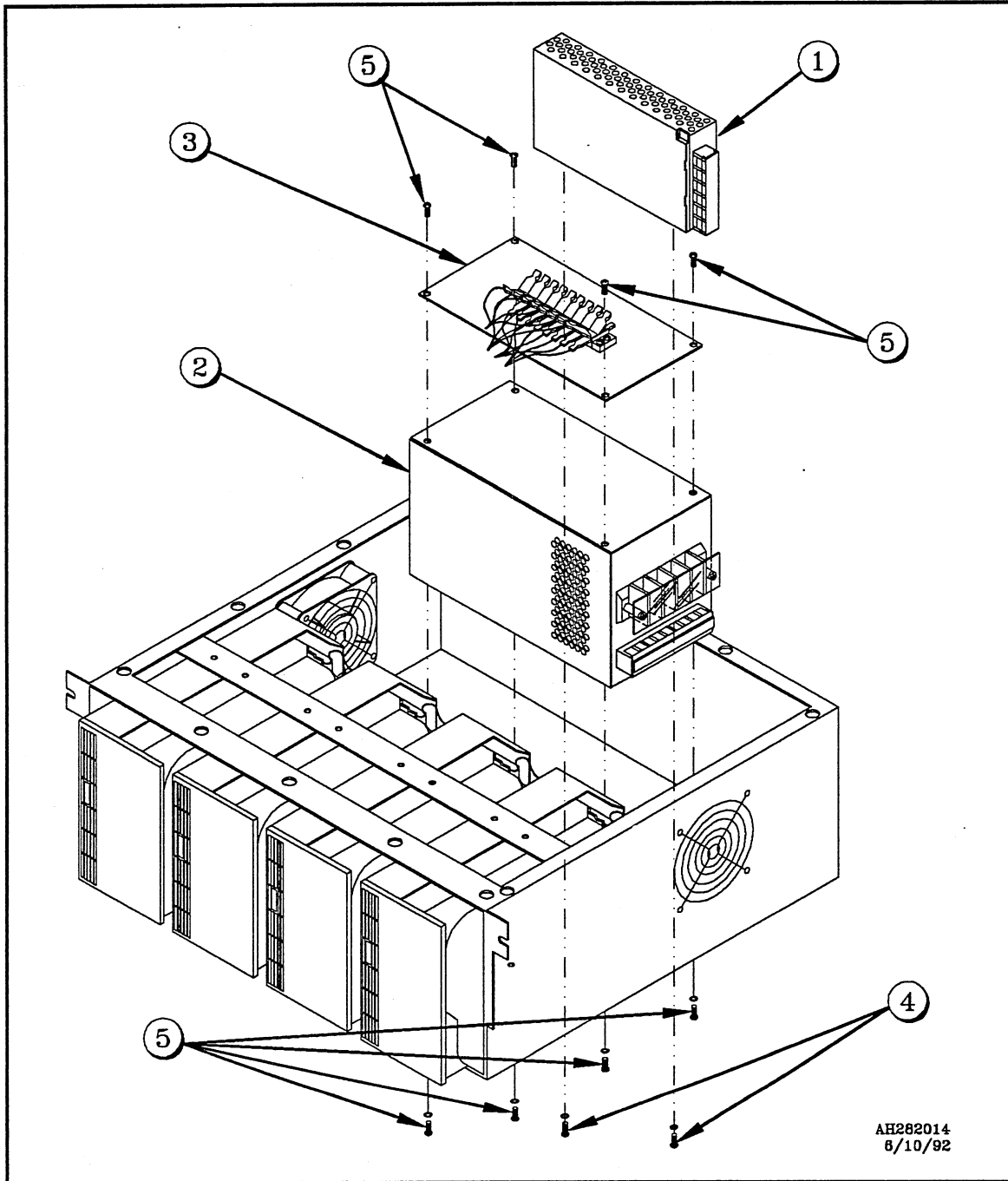

AH282014
6/10/92

Maintenance

Table 7

Fan, sensor, breaker and switch list

| Item number | CONVEX part number | Description |
|--------------------|---------------------------|---|
| 1 | 310-000431-006 | Fan assembly screws 8-32 x 1.375 inch |
| 2 | 310-100400-001 | Nut 8-32 |
| 3 | 230-000013-002 | Cooling fan finger guard |
| 4 | 230-000013-001 | Cooling fan |
| 5 | 310-000200-003 | Thermostat screw 4-40 x 1/4 inch |
| NA | 250-000013-002 | Thermostat |
| 6 | 500-000310-200 | Thermostat subassembly (recommended FRU) |
| 7 | 253-000113-003 | Circuit breaker |
| 8 | 125-000011-001 | ESDI chassis power switch |
| 9 | 310-002302-004 | Thermostat bracket screw 6-32 x 3/8 inch (chassis to bracket) |

Figure 24
Fan, sensor, breaker and switch IPB

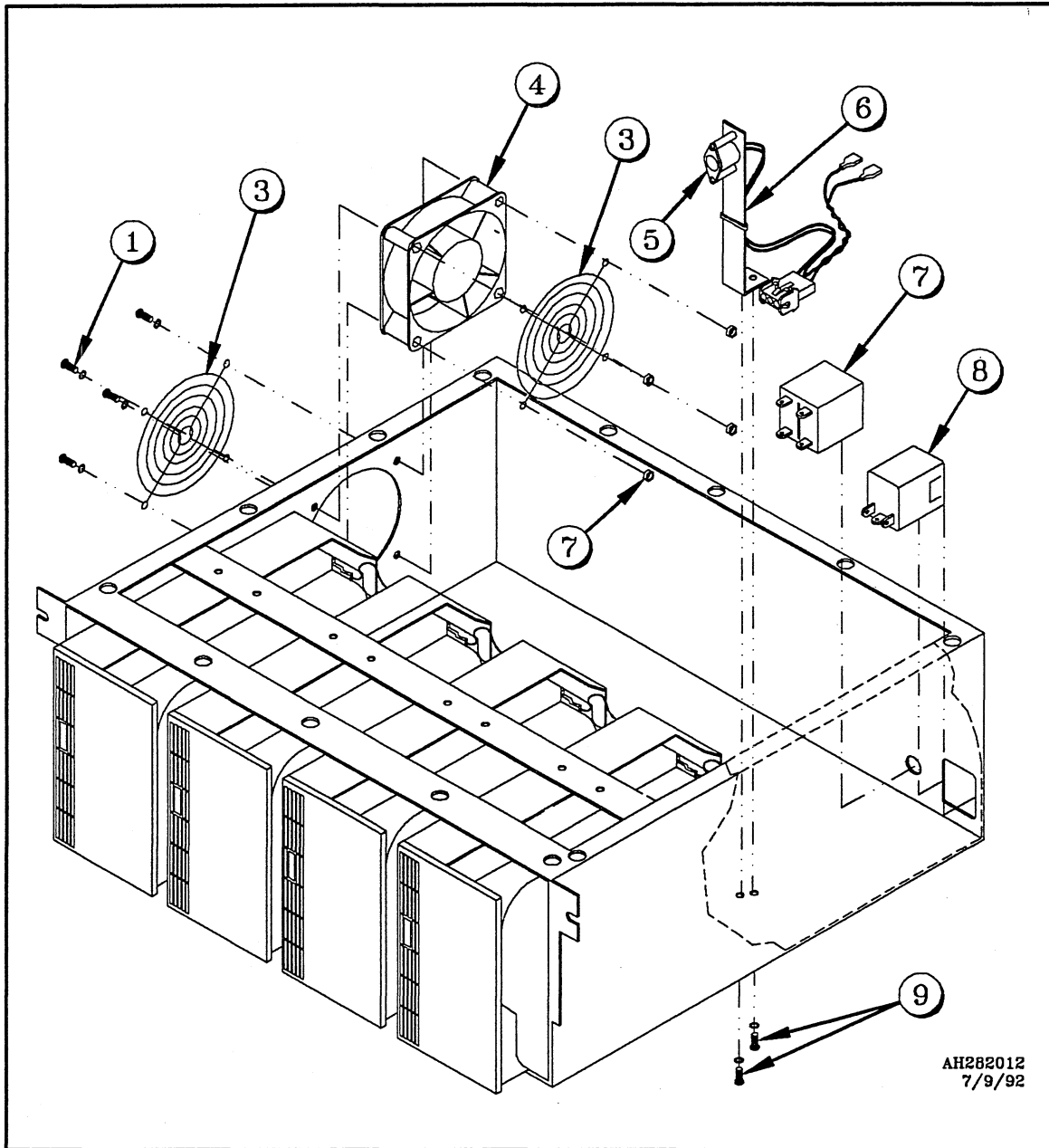

Maintenance

Table 8
Cabling list

| Item number | CONVEX part number | Description |
|--------------------|---------------------------|---|
| NA | 603-020059-200 | Fan dc power cable assembly |
| NA | 603-020001-200 | ac filter and chassis switch cable assembly |
| NA | 603-010029-200 | Ground strap cable assembly |
| NA | 603-040041-20[0-3] | 5-volt/12-volt dc power cable assembly |
| NA | 604-600002-201 | ESDI I/O control cable assembly |
| NA | 604-260003-201 | ESDI I/O data cable assembly |
| NA | 601-340013-200 | ESDI I/O control ribbon cable (4 drive) |
| NA | 601-340012-20[0-1] | ESDI I/O control ribbon cable (2 drive) |
| NA | 601-200007-20[0-3] | ESDI I/O data ribbon cable |

Table 9
Miscellaneous parts list

| Figure number | CONVEX part number | Description |
|---------------|--------------------|--|
| NA | 312-000345-001 | ESDI chassis slide rail (universal) |
| Figure 9 | 320-001461-500 | Front panel mounting bracket |
| Figure 9 | 312-000346-001 | Front panel mounting bracket grounding pads |
| Figure 1 | 320-001643-500 | ESDI chassis front panel |
| NA | 320-001645-500 | ESDI chassis front panel blank insert |
| NA | 310-150503-001 | RETMA rail nut |
| NA | 310-002501-001 | RETMA rail screw 10-32 x 1/2 inch. |
| NA | 320-001642-500 | Chassis |
| NA | 204-000025-001 | Resistor, Dip, ESDI terminator (RN11) (1.5-Gbyte drive only) |
| NA | 204-000025-002 | Jumper, 2-Pin, Configuration (1.5-Gbyte drive only) |

Hitachi 780MB ESDI Disc Drive Configurator

A

Overview

This appendix contains the *Hitachi 780MB ESDI Disc Drive Configurator Document* (effective 12/02/91). Note that a more recent version of this document may be available; check with the CONVEX Technical Assistance Center (TAC) for more information.

Hitachi 780MB ESDI Disc Drive Configurator Document

Section 1.0 Scope

This document provides configuration information for the Hitachi 780MB ESDI Disc Drive, Model Number DK515-78 (Convex P/N 204-000019-200).

Section 2.0 Disc Drive Configuration

Hitachi SZ931 P.C. Board Revision A/H1 and earlier Only

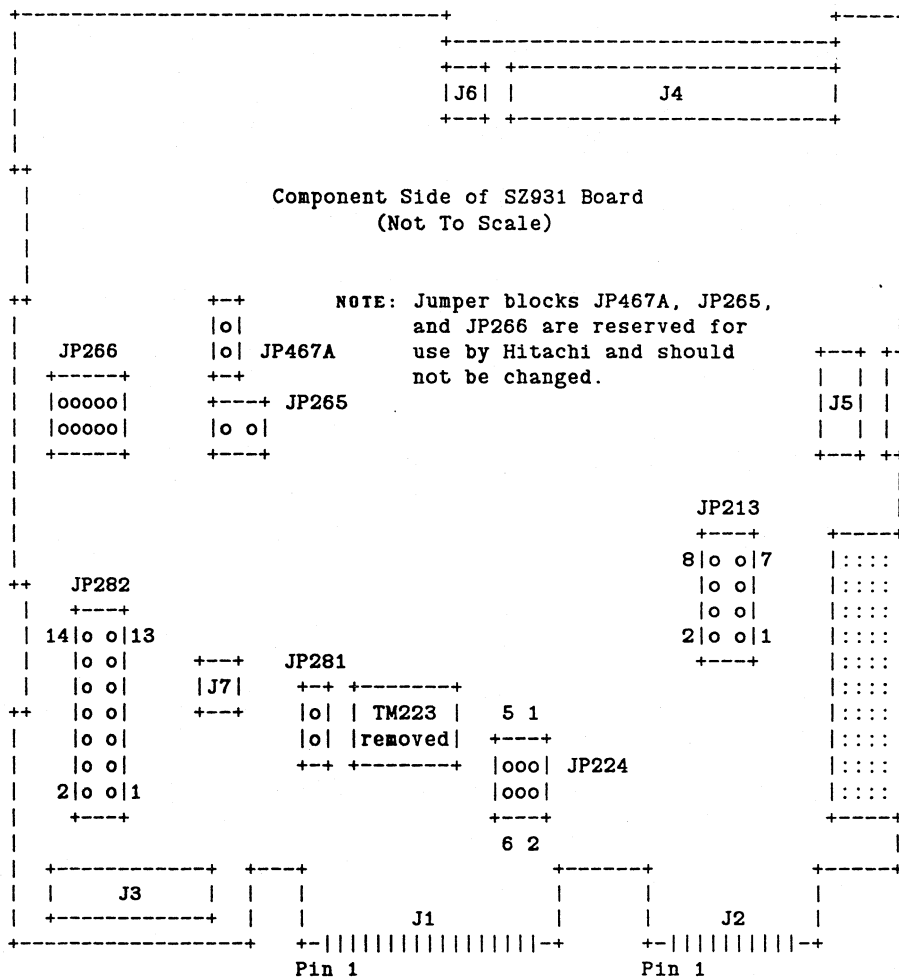

COMPANY CONFIDENTIAL. COPYRIGHT CONVEX COMPUTER CORPORATION 1992

| | | |
|---|--|------------------|
|  CONVEX | TITLE: Hitachi 780MB ESDI Disc Drive Configurator Document Part Number: 204-000019-600 | REV: D 12/02/91 |
| | | ENGR: Brad Jones |
| | | PAGE: 1 |

Hitachi 780MB ESDI Disc Drive Configurator Document

Section 3.0 Jumper Settings

The correct jumper settings are summarized in the following table:

| Jumper Location | Pins | Convex Setting | Jumper Description |
|------------------|------------------------|------------------|--|
| TM223 Terminator | | + | If RDS, the base unit provides termination, so this DIP must be removed. In other applications, terminate only the last drive in a daisy-chain. |
| JP213 | 1-2 3-4 5-6 | IN OUT OUT | These jumpers select the unit's Device Address. Device Address 1 (shown at left) is always used in the Convex RDS Subsystem. In other applications, Device Address 1 will be connected to Port 0 of the Interphase 4201. |
| JP213 | 1-2 3-4 5-6 | OUT IN OUT | Device Address 2 (non-RDS applications only), which connects to Port 1 of the Interphase 4201. |
| JP213 | 1-2 3-4 5-6 | IN IN OUT | Device Address 3 (non-RDS applications only), which connects to Port 2 of the Interphase 4201. |
| JP213 | 1-2 3-4 5-6 | OUT OUT IN | Device Address 4 (non-RDS applications only), which connects to Port 3 of the Interphase 4201. |
| JP213 | 7-8 | OUT | OUT enables writing; IN write protects the unit. |
| JP224 | 1-2 3-4 5-6 | + + + | All 3 jumpers OUT if the terminator is removed; all 3 jumpers IN if the terminator is installed. |
| JP281 | 1-2 | IN | IN terminates synchronous spindle signal. |
| JP282 | 1-2 | IN | IN selects hard sectoring; OUT selects soft. |
| JP282 | 3-4 5-6 | IN IN | IN/IN selects off-line sync spindle mode; OUT/IN slave; IN/OUT master; OUT/OUT remote. |
| JP282 | 7-8 | IN | IN doesn't start/stop spindle motor; OUT does. |
| JP282 | 9-10 11-12 13-14 | IN OUT IN | Selects 512 data bytes/sector, 69 sectors/track. |
| JP467A | ALL | + | SET BY HITACHI; DO NOT CHANGE |
| JP265 | ALL | + | SET BY HITACHI; DO NOT CHANGE |
| JP266 | ALL | + | SET BY HITACHI; DO NOT CHANGE |
| JP266A | ALL | + | SET BY HITACHI; DO NOT CHANGE |
| JP24A | ALL | + | SET BY HITACHI; DO NOT CHANGE |

COMPANY CONFIDENTIAL. COPYRIGHT CONVEX COMPUTER CORPORATION 1992

| | | |
|---|--|------------------|
|  CONVEX | TITLE: Hitachi 780MB ESDI Disc Drive Configurator Document Part Number: 204-000019-600 | REV: D 12/02/91 |
| | | ENGR: Brad Jones |
| | | PAGE: 4 |

Hitachi 780MB ESDI Disc Drive Configurator Document

DOCUMENT REVISION HISTORY

| REVISION | ECN NO. | DESCRIPTION | DATE | APPROVED |
|----------|---------|---|----------|----------|
| A | 106198 | Engineering Release. | 03/02/90 | |
| B | 106530 | Vendor ECN DK515EC-014 released Revision A/K2 SZ931 P.C. Board. | 06/26/90 | |
| C | 108030 | Added Device Address jumpering and Disc Termination specifications for applications other than RDS. | 08/16/91 | |
| D | 108427 | Added strapping points for Revision A/P3 artwork (Hitachi ECN DK515EC-018). | 12/02/91 | |

COMPANY CONFIDENTIAL. COPYRIGHT CONVEX COMPUTER CORPORATION 1992



CONVEX

TITLE: Hitachi 780MB ESDI Disc Drive
Configurator Document
Part Number: 204-000019-600

REV: D 12/02/91

ENGR: Brad Jones

PAGE: 5

Micropolis 1.53GB ESDI Disc Drive Configurator

B

Overview

This appendix contains *Micropolis 1.53GB ESDI Disc Drive Configurator Document* (effective 5/1/92). Note that a more recent version of this document may be available; check with the CONVEX Technical Assistance Center (TAC) for more information.

Micropolis 1.53GB ESDI Disc Drive Configurator Document

1.0 Scope

This document provides configuration information for the Micropolis Model 1518-15 1.53GB ESDI Disc Drive. Micropolis Part Number TS0051-01-8 (Convex Part Number 204-000025-200).

2.0 Disc Drive Configuration

Micropolis P.C. Board Layout

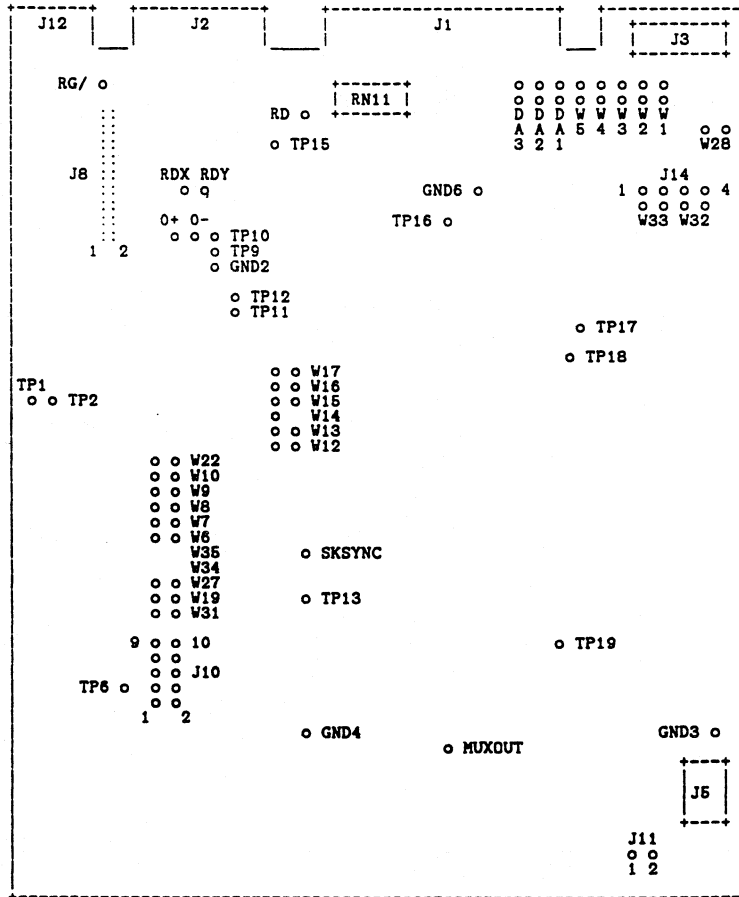

⇓ Front of Drive ⇓

COMPANY CONFIDENTIAL. COPYRIGHT CONVEX COMPUTER CORPORATION 1992



CONVEX

TITLE: Micropolis 1.53GB ESDI Disc Drive
Configurator Document
Part Number: 204-000025-600

REV: A 05/01/92

ENGR: Brad Jones

PAGE: 1

Micropolis 1.53GB ESDI Disc Drive Configurator Document

3.0 Jumper Settings

Normal Convex jumper settings are summarized in the following table:

| Jumper Location | Pins | Convex Setting | Jumper Description |
|----------------------|------|----------------|--|
| RN11 (Terminator) | | + | If RDS, the base unit provides termination, so this DIP must be removed. In other applications, terminate only the last drive in a daisy-chain. |
| DA1 | 1-2 | IN | These jumpers select the unit's Device Address. Device Address 1 (shown at left) is always used in the Convex RDS Subsystem. In applications other than RDS, Device Address 1 is connected to Port 0 of the Interphase 4201. |
| DA2 | 1-2 | OUT | |
| DA3 | 1-2 | OUT | |
| DA1 | 1-2 | OUT | Device Address 2 (non-RDS applications only), which connects to Port 1 of the Interphase 4201. |
| DA2 | 1-2 | IN | |
| DA3 | 1-2 | OUT | |
| DA1 | 1-2 | IN | Device Address 3 (non-RDS applications only), which connects to Port 2 of the Interphase 4201. |
| DA2 | 1-2 | IN | |
| DA3 | 1-2 | OUT | |
| DA1 | 1-2 | OUT | Device Address 4 (non-RDS applications only), which connects to Port 3 of the Interphase 4201. |
| DA2 | 1-2 | OUT | |
| DA3 | 1-2 | IN | |
| W1 | 1-2 | OUT | (Normal Usage) Soft Sector Disable. IN = Soft Sector Enable. |
| W2 | 1-2 | IN | These jumpers select the Bytes per Sector. All IN selects 597 Bytes per Sector. Reference the 1518-15 Technical Manual for other options. |
| W3 | 1-2 | IN | |
| W4 | 1-2 | IN | |
| W5 | 1-2 | OUT | (Normal Usage) Power-On starts Spindle. IN = Spindle Start upon Start Spindle command. |
| W12 | 1-2 | IN | (Normal Usage) These 5 jumpers must always be configured as shown for normal Read/Write operation. This configuration is altered for factory test only. |
| W13 | 1-2 | IN | |
| W15 | 1-2 | OUT | |
| W16 | 1-2 | IN | |
| W17 | 1-2 | OUT | |
| W28 | 1-2 | OUT | (Normal Usage) Frame to Logic Ground open. IN = Frame Ground connected to Logic Ground. |

COMPANY CONFIDENTIAL. COPYRIGHT CONVEX COMPUTER CORPORATION 1992



CONVEX

TITLE: Micropolis 1.53GB ESDI Disc Drive
Configurator Document
Part Number: 204-000025-600

REV: A 05/01/92

ENGR: Brad Jones

PAGE: 2

Micropolis 1.53GB ESDI Disc Drive Configurator Document

3.0 Jumper Settings (continued)

| Jumper Location | Pins | Convex Setting | Jumper Description |
|-----------------|------|----------------|---|
| W6 | 1-2 | → | These 11 jumpers are factory-configured to match the logic-to-HDA timing. Therefore, it will not be uncommon to find no two disc drives that are identically jumpered at these points. Do Not alter the factory configuration of these jumpers. |
| W7 | 1-2 | → | |
| W8 | 1-2 | → | |
| W9 | 1-2 | → | |
| W10 | 1-2 | → | |
| W19 | 1-2 | → | |
| W22 | 1-2 | → | |
| W27 | 1-2 | → | |
| W31 | 1-2 | → | |
| W32 | 1-2 | → | |
| W33 | 1-2 | → | |

4.0 Black Front Bezel Usage

Each disc drive will come with a Black Front Bezel (with Green LED), Convex Part Number 900-000614-001. Depending on the application where the disc drive is used, the Black Front Bezel may or may not be used.

In RDS Subsystems, the Black Front Bezel must be *removed* for proper air flow past the disc drive.

In other than RDS Subsystems, the Black Front Bezel must be *installed*.

DOCUMENT REVISION HISTORY

| REVISION | ECN NO. | DESCRIPTION | DATE |
|----------|---------|------------------|----------|
| A | 108939 | Initial Release. | 05/01/92 |

COMPANY CONFIDENTIAL. COPYRIGHT CONVEX COMPUTER CORPORATION 1992



CONVEX

TITLE: Micropolis 1.53GB ESDI Disc Drive
Configurator Document
Part Number: 204-000025-600

REV: A 05/01/92

ENGR: Brad Jones

PAGE: 3

Index

Symbols

/ioconfig file
figure 31

A

ac filter cable part number
table 55

B

block diagram
 ESDI subsystem, illustration 3
breaker part number
 chassis power, table 53
breaker, chassis power
 illustration 44, 52, 54
 removal 45
 replacement 46

C

cable
 ac filter part number, table 55
 chassis switch part number, table 55
 control 2
 date 2
 drive dc power cable part number, table 55
 ESDI drive part number, table 55
 Fan dc power, part number, table 55
 ground strap part number, table 55
 power supply cable part number, table 55
chassis
 specifications, table 4
chassis cooling fan
 finger guard, illustration 44
 illustration 44, 52, 54
 removal 45
 replacement 45
chassis cooling fan finger guard
 illustration 52, 54
 part number, table 53
chassis cooling fan part number
 table 53
chassis front panel blank insert part number
 table 56
chassis front panel part number
 table 56
chassis front view
 with four drives, illustration 2
chassis power breaker
 illustration 44, 52, 54
 part number, table 53
 removal 45
 replacement 46
chassis power switch
 illustration 44, 52, 54
 part number, table 53
 removal 46
 replacement 46
chassis slide rail part number
 table 56
chassis switch cable part number
 table 55
chassis temperature sensor
 illustration 44, 52, 54
 part number, table 53
 removal 47
 replacement 47
checklist
 unpacking 8
claims
 damage 9
configurator document 57, 61
CONVEX EXP-101 expansion cabinet
 power 10, 34
CONVEX EXP-102 expansion cabinet
 power 34
CONVEX EXP-102 expansion cabinet
 power 10
CONVEX EXP-105 expansion cabinet
 power 10, 35
ConvexOS
 software integration 29
 V8.1 29
cooling fan finger guard
 chassis, illustration 44, 52, 54

cooling fan finger guard part number
chassis, table 53
cooling fan part number
chassis, table 53
cooling fan, chassis
illustration 44, 52, 54
removal 45
replacement 45

D

damage
inspection for 8
damage claims 9
data transfer rate 1
dev5130 diagnostic 31
diagnostic
dev5130 31
DKC-203
VME ESDI disk controller 30
DKD-284
ESDI drive \ioconfig entry 30
DKD-287
ESDI drive \ioconfig entry 30
drive
illustration 50
specifications 4
specifications, table 4
testing 31
drive bracket
illustration 50
drive bracket part number
table 49, 51
drive dc power cable part number
table 55
drive installation
into a chassis 19
drive part number
table 49, 51
drive power supply
illustration 41
removal 42
replacement 42
drive unit
removal 39
replacement 39

E

electrostatic discharge
ESD 7
emphasis
italics for x
ESD damage
prevention 7
ESDI chassis
installation 14

ESDI disk drive
DKD-284 \ioconfig entry 30
DKD-287 \ioconfig entry 30
ESDI drive cable part number
table 55
ESDI subsystem
block diagram, illustration 3
expansion cabinet
stabilizer bars 12
CONVEX EXP-105 power 35
power 10
power removal 34
expansion cabinet stabilizer bars 35
illustration 36

F

fan dc power cable part number
table 55
file numbers
see log numbers
finger guard
chassis cooling fan, illustration 44, 52, 54
finger guard part number
chassis cooling fan, table 53
formatted capacity 1
front panel 10
front panel mounting bracket
grounding pads 17
front panel mounting bracket part number
table of 56

G

ground strap cable part number
table 55
grounding pads
front panel mounting bracket 17
grounding pads part number
table 56

I

illustrations
log numbers, convention for xi
inspection and unpacking 7
inspection for damage 8
installation
see also Preinstallation
ESDI chassis 14
overview 7
see also Postinstallation
installing a drive 19
/ioconfig file 30

L

log numbers
for illustrations xi

M

maintenance procedures 33
marketing numbers 30

O

operating system
requirements 2
overview
maintenance procedures and IPB 33
planning procedures 1, 57, 61
software integration and test 29
Specifications 1
unpacking and installation 7

P

packing
save for return shipping 8
part number
ac filter cable, table 55
chassis cooling fan finger guard, table 53
chassis cooling fan, table 53
chassis front panel blank insert, table 56
chassis front panel, table 56
chassis power breaker, table 53
chassis power switch, table 53
chassis slide rail, table 56
chassis switch cable, table 55
chassis temperature sensor, table 53
disk drive bracket, table 49, 51
drive dc power cable, table 55
drive, table 49, 51
ESDI drive cable, table 55
fan dc power cable, table 55
front panel mounting bracket, table 56
ground strap cable, table 55
grounding pads, table 56
power supply cable, table 55
power supply, table 49, 51
post service procedures 47
power
CONVEX EXP-101 expansion cabinet 10
CONVEX EXP-102 expansion cabinet 10
CONVEX EXP-105 expansion cabinet 10
expansion cabinet 10
VMEbus chassis 17
power breaker part number
chassis, table 53
power breaker, chassis

illustration 44, 52, 54
removal 45
replacement 46
power down
system 9, 33
power supply bracket
illustration 50
power supply cable part number
table 55
power supply part number
table 49, 51
power supply, drive
illustration 41, 50
removal 42
replacement 42
power switch
VMEbus chassis 11
VMEbus chassis, illustration 34
power switch part number
chassis, table 53
power switch, chassis
illustration 44, 52, 54
removal 46
replacement 46
preinstallation 9
preservice procedures 33

R

removal/replacement procedures 33
return shipping
save packing for 8

S

seek time
average 1
sensor
chassis temperature, removal 47
chassis temperature, replacement 47
service procedure
see Postservice procedures
service procedures
see Preservice procedures
shipping
save packing for return 8
software integration
ConvexOS 29
specifications
ESDI chassis, table 4
ESDI drive 4
ESDI drive, table 4
stabilizer bars
expansion cabinet 12, 35
expansion cabinet, illustration 36
switch
chassis power, illustration 44, 52, 54

chassis power, removal 46
chassis power, replacement 46
VMEbus chassis power 11
VMEbus chassis power, illustration 34
switch part number
chassis power, table 53
system power down 9, 33

T

temperature sensor part number
chassis, table 53
temperature sensor, chassis
illustration 44, 52, 54
removal 47
replacement 47
testing
dev5130 diagnostic 31
drive 31

U

unpacking
checklist 8
overview 7
unpacking and inspection 7

V

VME control module
1.5 Gbyte drive 17
VME ESDI disk controller
block diagram, illustration 3
DKC-203 \ioconfig entry 30
VMEbus chassis
power switch 11
power switch, illustration 34
VMEbus chassis power 17, 26

CONVEX COMPUTER CORPORATION

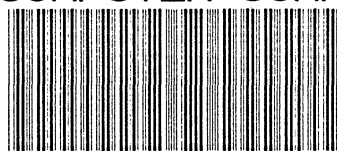

ESDI DISK SYSTEM SERVICE GUIDE
081-013730-001